

AQA Physics A-level

Section 7: Fields and their consequences

Notes



3.7.1 Fields

A **force field** is an area in which an object experiences a **non-contact force**. Force fields can be represented as **vectors**, which describe the direction of the force that would be exerted on the object, from this knowledge you can deduce the direction of the field. They can also be represented as diagrams containing **field lines**, the distance between field lines represents the strength of the force exerted by the field in that region.

Force fields are formed during the **interaction of masses, static charge or moving charges**.

Different types of fields are formed depending on which interaction takes place:

- **Gravitational fields** - formed during the interaction of masses
- **Electric fields** - formed during the interaction of charges

The forces these fields exert have a number of similarities and differences:

Similarities	Differences
Forces both follow an inverse-square law	In gravitational fields, the force exerted is always attractive, while in electric fields the force can be either repulsive or attractive.
Use field lines to be represented	
Both have equipotential surfaces	Electric force acts on charge, while gravitational force acts on mass.

3.7.2 Gravitational fields

3.7.2.1 - Newton's law

Gravity acts on any objects which have **mass** and is **always attractive**.

Newton's law of gravitation shows that the magnitude of the gravitational force between two masses is **directly proportional to the product of the masses**, and is **inversely proportional to the square of the distance between them**, (where the distance is measured between the two centres of the masses).

$$F = \frac{Gm_1m_2}{r^2}$$

Where G is the gravitational constant, m_1/m_2 are masses and r is the distance between the centre of the masses.

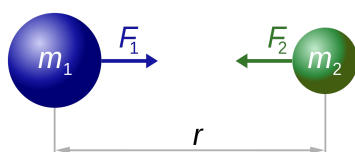

$$F_1 = F_2 = G \frac{m_1 \times m_2}{r^2}$$

Image source:

[I. Dennis Nilsson, CC BY 3.0](https://creativecommons.org/licenses/by/3.0/)



3.7.2.2 - Gravitational field strength

There are two types of gravitational field; a **uniform field** or **radial field**. These can be represented as the following field lines:

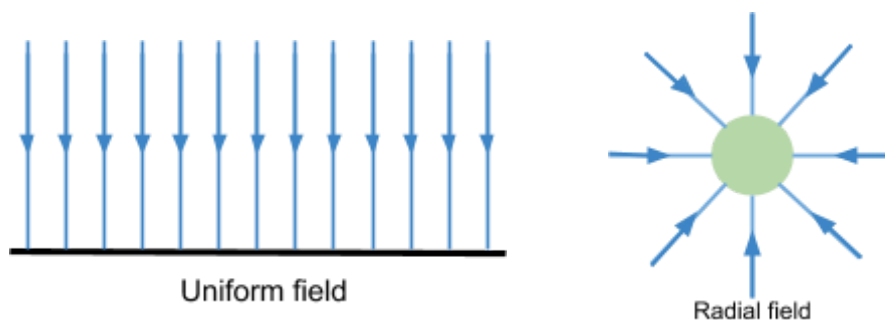

The arrows on the field lines show the direction that a force acts on a mass. A **uniform field** exerts the **same** gravitational force on a mass everywhere in the field, as shown by the parallel and equally spaced field lines. In a **radial field** the **force exerted depends on the position** of the object in the field, e.g in the diagram above, as an object moves further away from the centre, the magnitude of force would decrease because the distance between field lines decreases. The Earth's gravitational field is radial, however very close to the surface it is almost completely uniform.

Gravitational field strength (g) is the force per unit mass exerted by a gravitational field on an object. This value is constant in a uniform field, but varies in a radial field. There are two formulas you can use to calculate this; the first is general, while the second is used only for radial fields:

$$g = \frac{F}{m} \qquad g = \frac{GM}{r^2} \text{ (For radial fields only)}$$

3.7.2.3 - Gravitational potential

Gravitational potential (V) at a point is the **work done per unit mass when moving an object from infinity to that point**. Gravitational potential **at infinity is zero**, and as an object moves from infinity to a point, energy is released as the gravitational potential energy is reduced, therefore **gravitational potential is always negative**.

$$V = -\frac{GM}{r} \text{ (For a radial field)}$$

Where M is the mass of the object causing the field, r is the distance between the centres of the objects.

The **gravitational potential difference (ΔV)** is the **energy needed to move a unit mass between two points** and therefore can be used to find the work done when moving an object in a gravitational field.

$$\text{Work done} = m\Delta V \text{ Where } m \text{ is the mass of the object moved.}$$



Equipotential surfaces are surfaces which are created through joining points of equal potential together, therefore the **potential on an equipotential surface is constant everywhere**. As these points all have equal potential, the gravitational potential difference is zero when moving along the surface, so **no work is done when moving along an equipotential surface**. The red lines on the diagram to the right represent equipotential surfaces.

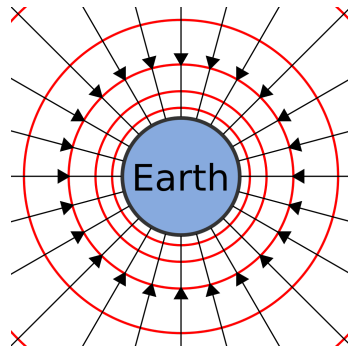

As shown by the equation for gravitational potential above, **gravitational potential (V) is inversely proportional to the distance between the centres of the two objects (r)**. This can be represented on a **graph of potential (V) against distance r**.

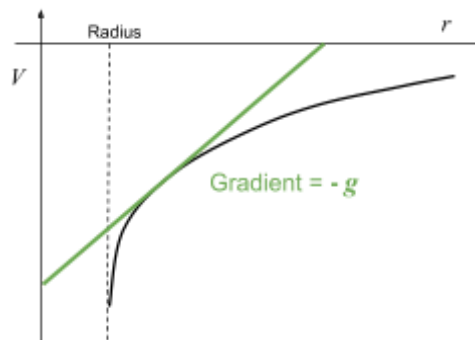

Gravitational field strength (g) at a certain distance can be measured by drawing a **tangent to the curve** at that distance and calculating its **gradient**, then **multiplying by -1**:

$$g = \frac{-\Delta V}{\Delta r}$$

If you plot a graph of **gravitational field strength (g) against distance (r)**, you can find the **gravitational potential difference** by finding the **area under the curve**.

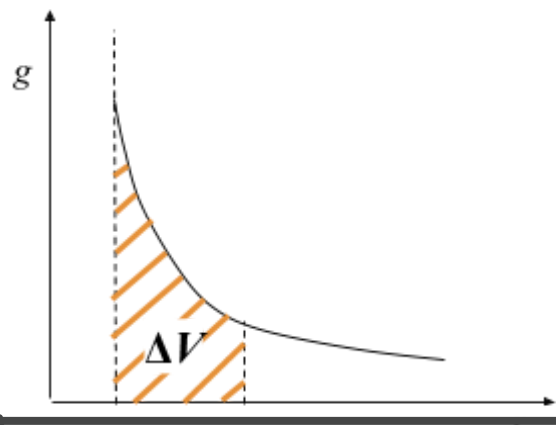

3.7.2.4 - Orbits of planets and satellites

Kepler's third law is that the **square of the orbital period (T) is directly proportional to the cube of the radius (r)**: $T^2 \propto r^3$. This can be derived through the following process:

1. When an object orbits a mass, it experiences a **gravitational force** towards the centre of the mass, and as the object is moving in a circle, this gravitational force acts as the **centripetal force**. Therefore we can **equate** the equations of centripetal force and gravitational force:

$$\text{Centripetal force} = \frac{mv^2}{r} \quad \text{Gravitational force} = \frac{GMm}{r^2}$$

$$\frac{mv^2}{r} = \frac{GMm}{r^2}$$

2. Rearrange the equation to make it v^2 the subject.

$$v^2 = \frac{GM}{r}$$

3. Velocity is the **rate of change of displacement**, therefore you can find v in terms of radius (r) and orbital period (T):

$$v = \frac{2\pi r}{T} \quad \Rightarrow \quad v^2 = \frac{4\pi^2 r^2}{T^2}$$

Because the diameter of a circle is $2\pi r$, and the object will travel this distance in one orbital period.

4. Substitute the equation for v^2 in terms of r and T , into the original equation (from step 2).

$$\frac{4\pi^2 r^2}{T^2} = \frac{GM}{r}$$

5. Rearrange to make T^2 the subject.

$$T^2 = \frac{4\pi^2}{GM} \times r^3$$

As $\frac{4\pi^2}{GM}$ is a constant, this shows that **$T^2 \propto r^3$ (T^2 is directly proportional to r^3)**.

The **total energy** of an orbiting satellite is made up of its **kinetic and potential energy**, and is **constant**. For example, if the height of a satellite is decreased, its gravitational potential energy will decrease, however it will travel at a higher speed meaning kinetic energy increases, therefore total energy is always kept constant.

$$\text{Total energy of a satellite} = \text{kinetic energy} + \text{potential energy}$$



The **escape velocity** of an object is the **minimum velocity it must travel at, in order to escape the gravitational field at the surface of a mass**. This is the velocity at which the object's **kinetic energy is equal to the magnitude of its gravitational potential energy**.

$$E_k = E_p$$

$$\frac{1}{2}mv^2 = \frac{GMm}{r} \quad \text{As gravitational potential energy} = m\Delta V$$

$$\Rightarrow v = \sqrt{\frac{2GM}{r}}$$

From the above equation, you can see that the escape velocity is independent of the mass of the object.

A **synchronous orbit** is one where the **orbital period of the satellite is equal to the rotational period of the object that it is orbiting**, for example a synchronous satellite orbiting Earth would have an **orbital period of 24 hours**.

Geostationary satellites follow a specific geosynchronous orbit, meaning their orbital period is **24 hours** and they always stay above the **same point** on the Earth, because they **orbit directly above the equator**. These types of satellites are very useful for sending **TV and telephone signals** because it is always above the same point on the Earth so you don't have to alter the plane of an aerial or transmitter.

In order to find the orbital radius of a geostationary satellite you can use the relationship that was derived above:

$$T^2 = \frac{4\pi^2}{GM} \times r^3 \Rightarrow r^3 = \frac{GMT^2}{4\pi^2}$$

$$r^3 = \frac{6.67 \times 10^{-11} \times 5.97 \times 10^{24} \times (24 \times 60 \times 60)^2}{4\pi^2} = 7.53 \times 10^{22} \text{ m}^3$$

$$r = 4.2 \times 10^7 \text{ m}$$

Which is around 36 000 km above the Earth's surface.

Low-orbit satellites have significantly lower orbits in comparison to geostationary satellites, therefore they **travel much faster** meaning their **orbital periods are much smaller**. Because of this, these satellites require less powerful transmitters and can potentially orbit across the entire Earth's surface, this makes them useful for **monitoring the weather, making scientific observations about places which are unreachable and military applications**. They can also be used for communications but because they travel so quickly, many satellites must work together to allow constant coverage for a certain region.



3.7.3 Electric fields

3.7.3.1 - Coulomb's law

Coulomb's law states that the magnitude of the force between two point charges in a **vacuum** is **directly proportional to the product of their charges**, and **inversely proportional to the square of the distance** between the charges.

$$F = \frac{1}{4\pi\epsilon_0} \frac{Q_1 Q_2}{r^2}$$

Where ϵ_0 is the permittivity of free space, Q_1/Q_2 are charges, r is the distance between charges.

Air can be treated as a vacuum when using the above formula, and for a charged sphere, **charge may be assumed to act at the centre of the sphere**.

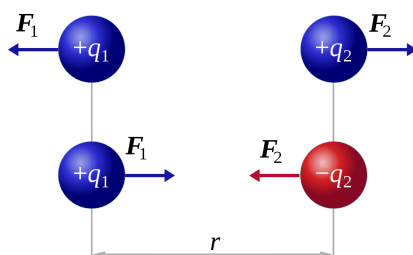

Image source: [Dna-Dennis, CC BY 3.0](https://www.dnadenis.com/), Image is cropped

If charges have the **same** sign the force will be **repulsive**, and if the charges have **different** signs the force will be **attractive**.

The **magnitude of electrostatic forces between subatomic particles is magnitudes greater than the magnitude of gravitational forces**, this is because the masses of subatomic particles are incredibly small whereas their charges are much larger.

For example, consider the gravitational and electrostatic force between two protons, with centres 2 pm (2×10^{-12} m) apart.

- **Gravitational force**, $F = \frac{GMm}{r^2}$:

$$F = \frac{6.67 \times 10^{-11} \times 1.67 \times 10^{-27} \times 1.67 \times 10^{-27}}{(2 \times 10^{-12})^2} = 4.65 \times 10^{-41} \text{ N}$$
- **Electrostatic force**, $F = \frac{1}{4\pi\epsilon_0} \frac{Q_1 Q_2}{r^2}$:

$$F = \frac{1}{4\pi \times 8.85 \times 10^{-12}} \times \frac{1.6 \times 10^{-19} \times 1.6 \times 10^{-19}}{(2 \times 10^{-12})^2} = 5.75 \times 10^{-5} \text{ N}$$
- **Ratio of electric force over gravitational force**, $\frac{F_{\text{electric}}}{F_{\text{gravitational}}}$

$$\frac{5.75 \times 10^{-5}}{4.65 \times 10^{-41}} = 1.24 \times 10^{36}$$

Therefore the electrostatic force between the two protons is 1.24×10^{36} times greater than the gravitational force.



3.7.3.2 - Electric field strength

Electric field strength (E) is the force per unit charge experienced by an object in an electric field. This value is constant in a uniform field, but varies in a radial field. There are three formulas you can use to calculate this value; the first is general, the second is used to find the magnitude of E in a uniform field formed by two parallel plates, while the third is used only for radial fields:

$$E = \frac{F}{Q} \quad E = \frac{V}{d} \text{ (for uniform fields formed by parallel plates)} \quad E = \frac{1}{4\pi\epsilon_0} \frac{Q}{r^2} \text{ (for radial fields)}$$

Where V is the potential difference across the plates, d is the distance between the plates, ϵ_0 is the permittivity of free space, Q is the magnitude of charge, r is the distance between charges.

Like gravitational fields, electric fields can be uniform or radial and can also be represented by the following field lines:

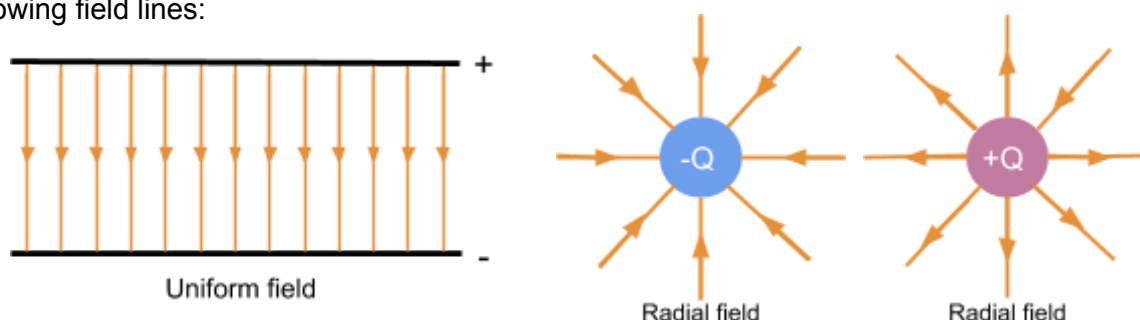

The field lines show the direction of the force acting on a **positive** charge. A **uniform field** exerts that **same** electric force everywhere in the field, as shown by the parallel and equally spaced field lines, whereas in a **radial field** the magnitude of electric force **depends on the distance** between the two charges.

You can derive an equation to calculate the **work done** by **moving a charged particle between the parallel plates** of a uniform field using the equations for electric field strength defined above:

$$\text{Work done} = F \times d$$

$$\text{Rearrange } E = \frac{F}{Q} \text{ to get F as the subject. } F = EQ$$

$$\text{Rearrange } E = \frac{\Delta V}{d} \text{ to get d as the subject. } d = \frac{\Delta V}{E}$$

Substitute the above values into the general formula for work done:

$$\text{Work done} = EQ \times \frac{\Delta V}{E} \quad \text{Work done} = Q\Delta V$$

Uniform electric fields made by two parallel plates can sometimes be used to find out whether a particle is charged, and whether its charge is negative or positive. This is done by firing the particle at right angles to the field and observing its path: a charged particle will experience a **constant electric force** either in or opposite to the direction of the field (depending on its charge), this causes the particle to **accelerate** and so it follows a **parabolic shape**. If the charge on the particle is positive it will follow the direction of the field, if the charge is negative it will move opposite to the direction of the field.



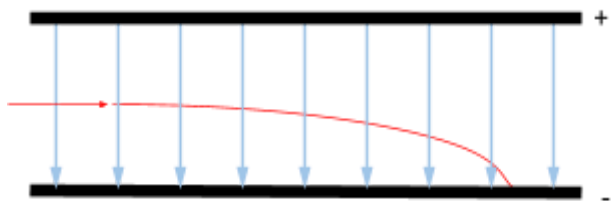

For example, in the diagram to the left, the particle must have a positive charge as it follows a parabolic shape in the direction of the field.

3.7.3.3 - Electric potential

Absolute electric potential (V) at a point is the **potential energy per unit charge of a positive point charge at that point** in the field. The absolute magnitude of electric potential is **greatest at the surface of a charge**, and as the distance from the charge increases, the potential decreases so **electric potential at infinity is zero**. To find the value of potential in a **radial field** you can use

the formula:

$$V = \frac{1}{4\pi\epsilon_0} \frac{Q}{r}$$

Where ϵ_0 is the permittivity of free space, Q is the charge, r is the distance from the charge.

Whether the value of potential is negative or positive depends on the sign of the charge (Q), when the charge is positive, **potential is positive and the charge is repulsive**, when the charge is negative, **potential is negative and the force is attractive** (similarly to gravitational potential which is always attractive).

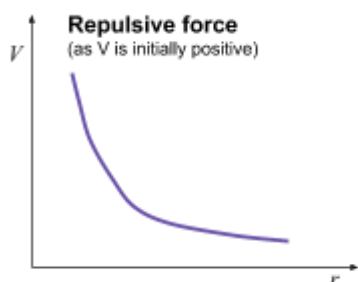

The **gradient of a tangent to a potential (V) against distance (r) graph**, gives the value of **electric field strength (E)** at that point:

$$E = \frac{\Delta V}{\Delta r}$$

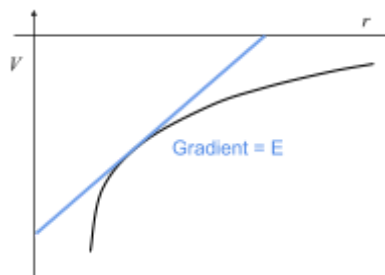

Electric potential difference (ΔV) is the **energy needed to move a unit charge between two points**. Therefore, the work done (ΔW) in moving a charge across a potential difference is equal to the product of potential difference and charge.

$$\Delta W = Q\Delta V$$

Electric fields have **equipotential surfaces**, just like gravitational fields. The potential on an equipotential surface is the same everywhere, therefore **when a charge moves along an equipotential surface, no work is done**. Between two parallel plates the equipotential surfaces are planes which are equally spaced and parallel to the plates, whereas equipotential surfaces around a point charge form concentric circles.

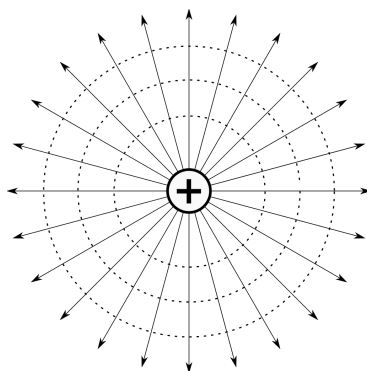
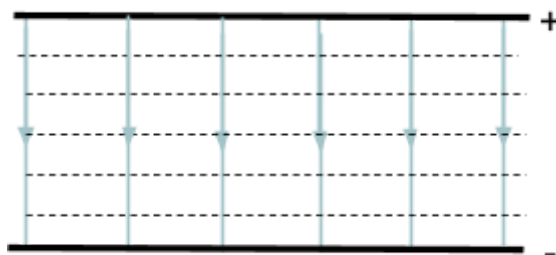
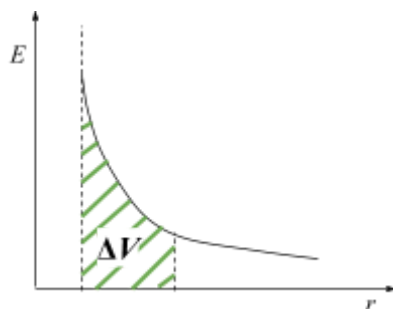

Image source: [Balajijagadesh, CC BY-SA 4.0](https://www.balajijagadesh.com)

If you plot a graph of **electric field strength (E) against distance (r)**, you can find the **electric potential difference** by finding the **area under the graph**.



3.7.4 Capacitance

3.7.4.1 - Capacitance

Capacitance (C) is the **charge stored (Q) by a capacitor per unit potential difference (V)**.

$$C = \frac{Q}{V}$$

3.7.4.2 - Parallel plate capacitor

A **capacitor** is an electrical component which **stores charge**. It is made up of **two conducting parallel plates** with a gap between them which may be separated by an insulating material known as a **dielectric**. When the capacitor is connected to a source of power, opposite charges build up on the two parallel plates causing a **uniform electric field** to be formed.

Dielectrics have a property called **permittivity (ϵ)**, which is a measure of the **ability to store an electric field in the material**. Using this value, you can find the **relative permittivity (ϵ_r)**, also known as the **dielectric constant** of a dielectric, which is used to calculate the capacitance of a capacitor. You can calculate relative permittivity by finding the **ratio of the permittivity of the dielectric to the permittivity of free space**:

$$\epsilon_r = \frac{\epsilon}{\epsilon_0}$$

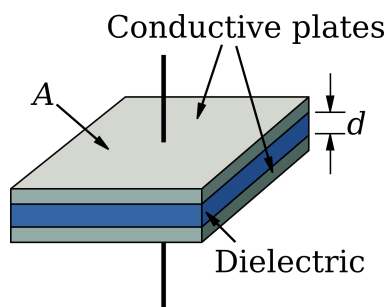

The **capacitance** of a capacitor (C) can be calculated by measuring the area of the plates (A), the distance between the plates (d), and the **relative permittivity (ϵ_r)** of the dielectric in the gap of the capacitor:

$$C = \frac{A\epsilon_0\epsilon_r}{d}$$

A dielectric is formed of **polar molecules**, which are molecules with one end which is positive and one which is negative (these are demonstrated by the orange ovals on the diagram below). Usually, when there is no electric field, these molecules are arranged in random directions, however when an electric field is present these polar molecules will move and **align themselves with the field**, as shown in the diagram. The negative ends will be rotated towards the positive plate of the capacitor and the positive ends to the negative plate; **each molecule has its own electric field, the strength of which depends on the dielectric's permittivity**, which will **now oppose the field formed by the capacitor, reducing this field**. Due to this, the **potential**



difference required to charge the capacitor decreases (as electric field strength is decreased), causing **capacitance to increase** because $C = \frac{Q}{V}$.

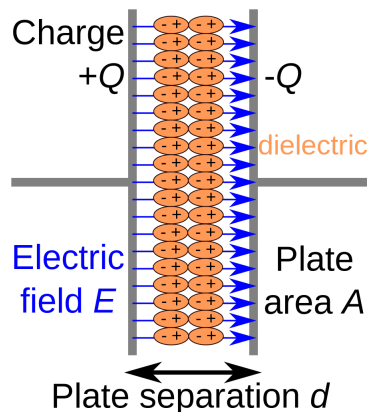
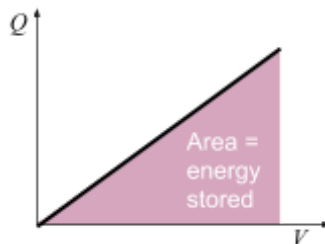

Image source: [Papa November, CC BY-SA 3.0](#)

3.7.4.3 - Energy stored by a capacitor

The electrical **energy stored by a capacitor (E)** is given by the **area under a graph of charge (Q) against potential difference (V)**. As potential difference is directly proportional to charge, this graph forms a straight line through the origin, so the area underneath it is a right angle triangle so:

$$E = \frac{1}{2}QV$$



You can substitute the formula for capacitance ($C = \frac{Q}{V}$) into the above equation to get two more variations of it, which can be used to find the energy stored:

$$E = \frac{1}{2}QV = \frac{1}{2}CV^2 = \frac{Q^2}{2C}$$



3.7.4.4 - Capacitor charge and discharge

In order to charge a capacitor you must connect it in a circuit with a power supply and resistor, as shown in the circuit diagram below:

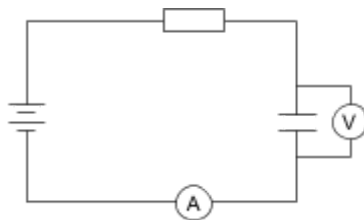

You could use a data logger to measure the values of potential difference and current in order to plot a **graph of voltage and current against time**. As $Q = I \times t$, you can draw a graph of **charge against time** by measuring the **area under the current-time graph**.

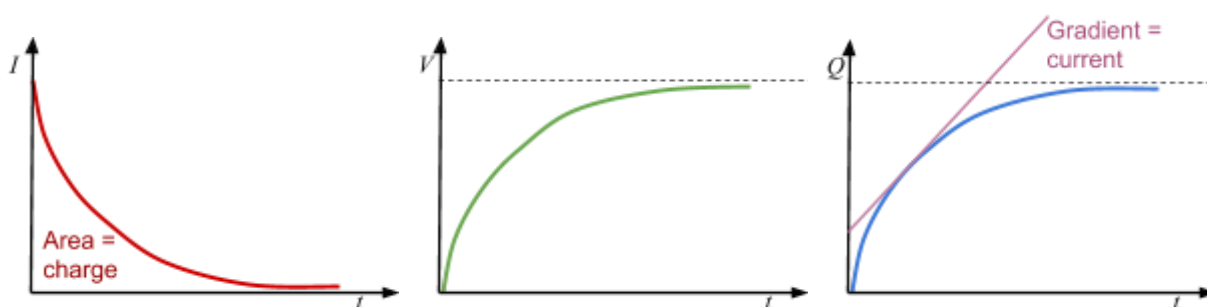

Once the capacitor is connected to a power supply, current starts to flow and **negative charge builds up on the plate** connected to the negative terminal. On the opposite plate, electrons are repelled by the negative charge building up on the initial plate, therefore these **electrons move to the positive terminal** and an **equal but opposite charge is formed on each plate**, creating a potential difference. As the **charge across the plates increases, the potential difference increases but the electron flow decreases** due to the force of electrostatic repulsion also increasing, therefore current decreases and eventually reaches zero.

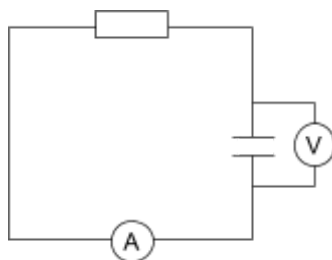

To discharge a capacitor through a resistor, you must connect it to a closed circuit with just a resistor.

Again you could use a data logger to measure voltage and current to plot graphs of **voltage, current and charge against time**.



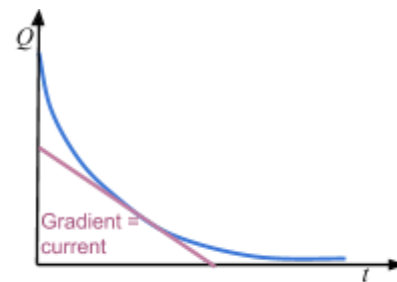
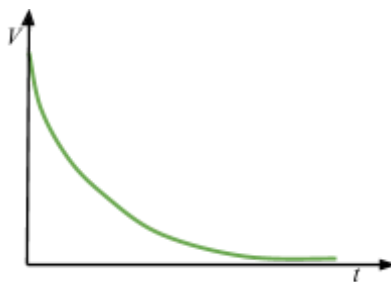
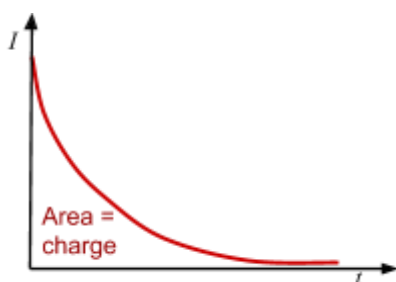

When the capacitor is discharging the **current flows in the opposite direction**, and **the current, charge and potential difference across the capacitor will all fall exponentially**, meaning it will take the same amount of time for the values to halve.

The graphs of charge, potential difference and current against time all follow exponential curves for capacitor charging and discharging, meaning there are equations involving an exponential function to calculate these values:

	Charging	Discharging
Current (I)	$I = I_0 e^{-\frac{t}{RC}}$	$I = I_0 e^{-\frac{t}{RC}}$
Potential difference (V)	$V = V_0 (1 - e^{-\frac{t}{RC}})$	$V = V_0 e^{-\frac{t}{RC}}$
Charge (Q)	$Q = Q_0 (1 - e^{-\frac{t}{RC}})$	$Q = Q_0 e^{-\frac{t}{RC}}$

Where I_0 is initial current, V_0 is initial voltage, Q_0 is initial charge, t is time, C is capacitance and R is resistance of the charge/discharge circuit.

The **product of resistance and capacitance (RC)** is known as the **time constant**, and this is the value of time taken to:

- Discharge a capacitor to $\frac{1}{e} \approx 0.37$ of its initial value (of charge, current or voltage)
- Charge a capacitor to $(1 - \frac{1}{e}) \approx 0.63$ of its initial value (of charge or voltage)

You can derive the above values by using the value of time constant as the time passed in the equations in the table above.



You can **calculate the time constant from graphs of current, charge and voltage against time**, by **finding the time where the values are either 0.37 of the initial value if discharging or 0.63 of the maximum value if charging** (for charge or voltage), as shown in the graphs below.

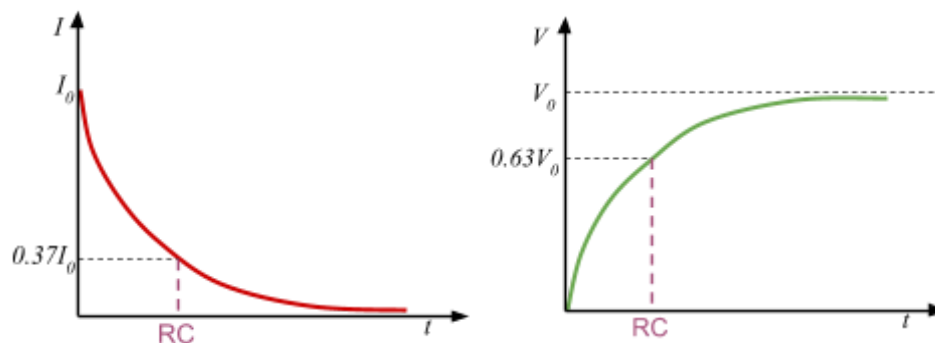

Another way to find the value of the time constant is to use **log graphs** from the data you collect.

Firstly, take the natural log of both sides of the discharging equation for charge:

$$\ln Q = \ln(Q_0 e^{-\frac{t}{RC}})$$

$$\ln Q = \ln Q_0 - \frac{t}{RC} \quad (\text{using the rules: } \log(ab) = \log(a) + \log(b) \text{ and } \ln(e) = 1)$$

If you plot a graph of $\ln(Q)$ against t , the **gradient of this graph is $-\frac{1}{RC}$** , therefore $RC = \frac{-1}{\text{gradient}}$.

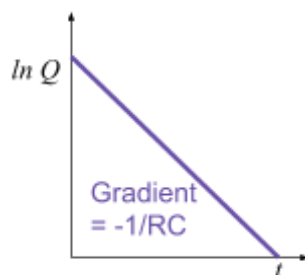

The **time to halve ($T_{1/2}$)** is the time taken for the **current, charge or potential difference of a capacitor to discharge to half of the initial value**.

You can derive a formula for time to halve by considering one discharge equation e.g. the current equation and letting the value of current equal $0.5 I_0$, and solving for time:

$$0.5I_0 = I_0 e^{-\frac{t}{RC}} \quad \text{Divide through by } I_0$$

$$0.5 = e^{-\frac{t}{RC}} \quad \text{Take natural logs of both sides}$$

$$\ln 0.5 = \frac{-t}{RC} \quad \text{Rearrange to make } t \text{ the subject}$$

$$t = -\ln(0.5) \times RC \quad -\ln 0.5 \approx 0.69 \quad T_{1/2} = 0.69RC$$

Below are some example questions using the above equations:

Find the approximate value of time constant for the capacitor charging graph below:



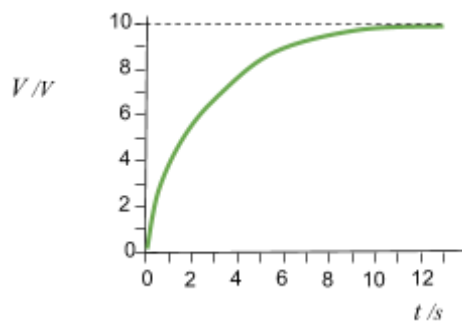

Firstly, draw a line across at 63% of its maximum value as the time at which this occurs will be the time constant. Read off the value for time at this point.

The value of time constant is approximately **2.5 s**.

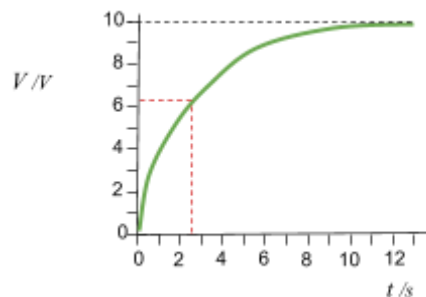

A capacitor with capacitance 600 nF is discharged through a 100kΩ resistor, find the time taken for voltage to halve from its initial value.

Use the formula $T_{1/2} = 0.69RC$.

$$T_{1/2} = 0.69 \times 600 \times 10^{-9} \times 100 \times 10^3 = \mathbf{0.0414 \text{ s}}$$

A capacitor with a capacitance of 300 μF is discharged through a 400 kΩ resistor, its initial value of charge is 5 C, find the value of charge after 5 s.

Use the formula $Q = Q_0 e^{-\frac{t}{RC}}$.

$$Q = 5 \times e^{-\frac{5}{300 \times 10^{-6} \times 400 \times 10^3}} = 5 \times e^{-\frac{5}{120}} = \mathbf{4.8 \text{ C}}$$



3.7.5 Magnetic fields

3.7.5.1 - Magnetic flux density

When **current passes through a wire**, a magnetic field is induced - this is true for any long, straight current-carrying conductor. This field lines of the induced magnetic field form **concentric rings** around the wire.

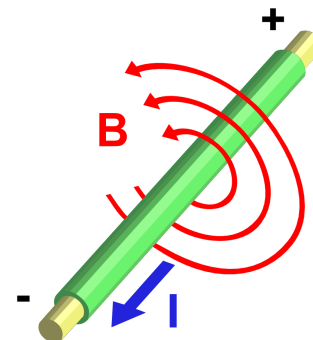

Image source: [Stannered, CC BY-SA 3.0](#)

The **magnetic flux density (B)** of a magnetic field, is a measure of the strength of the field, and it is measured in the unit Tesla. **One Tesla** is defined as a force of 1 N on 1 metre of wire carrying 1 A of current perpendicular to a magnetic field.

When a current-carrying wire is placed in a magnetic field, **a force is exerted on the wire**. However, if the **current is parallel to the magnetic field**, the force is **0 N**, because no component of the field is perpendicular to the current. To find the magnitude of force (F) when the wire of length l , carrying a current I , is placed into a field of flux density B , so that **field is perpendicular to the current**, you can use the formula:

$$F = BIl$$

To find the direction of the force exerted on the wire you can use **fleming's left hand rule**. Spread out your thumb, first and second finger so that they are all **perpendicular** to each other, each finger represents a different quantity:

- **ThuMb** - represents the direction of the **Motion**/force
- **First finger** - represents the direction of the **Field**
- **SeCond finger** - represents the direction of the **Conventional Current** (opposite direction to electron flow)

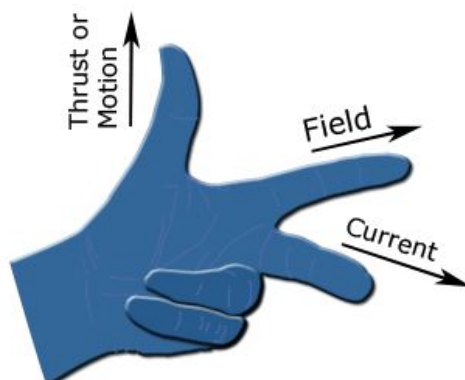

Image source: [Douglas Morrison DougM, CC BY-SA 3.0](#)

To use this rule simply point the respective finger in the direction of two known values, for example conventional current and field, to find the direction of the third, in this case motion/force.



The direction of a magnetic field on a magnet, is from its North pole to its South pole.

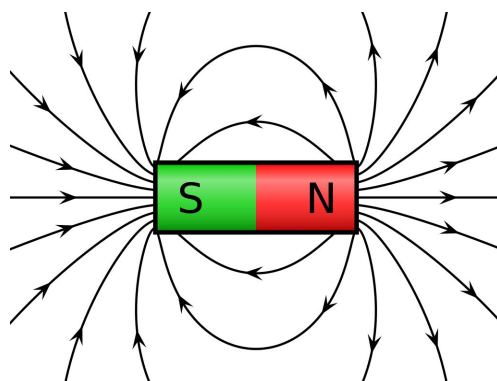

Image source: [Geek3](https://www.geek3.com/), CC BY-SA 3.0

3.7.5.2 - Moving charges in a magnetic field

A force acts on charged particles moving in a magnetic field, this is why a force is exerted on a current-carrying wire, because it contains moving electrons, which are negatively charged particles. The **magnitude of force (F)** exerted on a particle with charge Q , moving at a velocity v , **perpendicular** to a field with flux density B , can be calculated using the following formula:

$$F = BQv$$

To find the direction of motion/force exerted you can use **Fleming's left hand rule**, using the **second finger as the direction of travel**, however if the **charge on the particle is negative**, **reverse the direction of your second finger**, because the second finger represents **Conventional Current**, which flows from positive to negative.

The force exerted is **always perpendicular to the motion of travel**, which causes the charged particles to follow a **circular path** when in the magnetic field, because the force induced by the magnetic field acts as a centripetal force. By combining the formulas for centripetal force and magnetic force on a charged particle, you can find a formula to find the radius of the particle's circular path:

$$F = BQv \qquad F = \frac{mv^2}{r}$$

$$BQv = \frac{mv^2}{r}$$

$$r = \frac{mv}{BQ}$$

Where m is the particle's mass, v is the particle's velocity, Q is its charge and B is the magnetic flux density.

An application of the circular deflection of charged particles in a magnetic field is a type of particle accelerator called a **cyclotron**, which have many uses including producing ion beams for radiotherapy, and radioactive tracers.



A cyclotron is formed of **two semi-circular electrodes** called “Dees”, with a **uniform magnetic field** acting **perpendicular** to the plane of the electrodes, and a high frequency **alternating voltage** applied between the electrodes. The charged particles move from the **centre** of one of the electrodes, and are deflected in a circular path by the magnetic field. (Because the force exerted by the magnetic field is always perpendicular to the direction of travel, the **particle’s speed will not increase due to the magnetic field**, which is why there is an alternating electric field between the electrodes).

Once the particles reach the edge of the electrode they begin to move across the gap between the electrodes, where they are **accelerated by the electric field**, meaning the **radius of their circular path will increase** as they move through the second electrode. When the particles reach the gap again, the **alternating electric field changes direction allowing the particles to be accelerated again**. This process repeats several times until the required speed is reached by the particles and they exit the cyclotron.

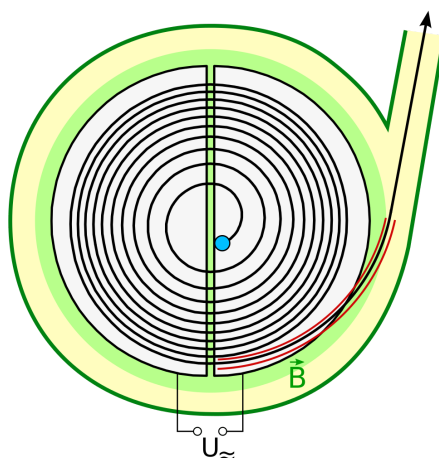

3.7.5.3 - Magnetic flux and flux linkage

Magnetic flux (Φ) is a value which describes the **magnetic field or magnetic field lines passing through a given area**, and it is calculated by finding the **product of magnetic flux density (B) and the given area (A)**, when the field is **perpendicular to the area**:

$$\Phi = BA$$

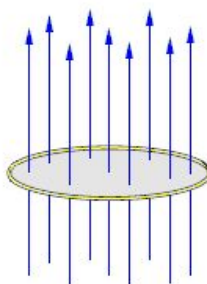

Image source: [Croquant](https://www.croquant.com/), CC BY-SA 3.0



Magnetic flux linkage ($N\Phi$) is the **magnetic flux** multiplied by the **number of turns N** , of a coil:

$$N\Phi = BAN$$

If the magnetic field is not perpendicular to a coil of wire, you can still find magnetic flux and magnetic flux linkage by using **trigonometry** to **resolve the magnetic field vector into components**, which are **parallel and perpendicular to the coil**.

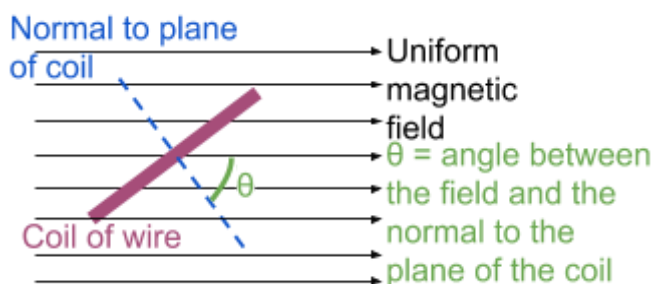

The component of the field **parallel to the coil will give a magnetic flux of 0 Wb**, therefore **only the perpendicular component is required** to calculate magnetic flux. As seen in the diagram to the left, the value of magnetic flux would be:

$$\Phi = BA \cos \theta$$

Therefore, the value of magnetic flux linkage would be given by:

$$N\Phi = BAN \cos \theta$$

3.7.5.4 - Electromagnetic induction

When a **conducting rod moves relative to a magnetic field**, the electrons in the rod will experience a force (as they are charged particles), and build up on one side of the rod, causing an **emf to be induced** in the rod, this is known as **electromagnetic induction**. This phenomenon also occurs if you move a bar magnet relative to a coil of wire, **if the coil forms a complete circuit, a current is also induced**.

There are two laws which govern the effects of **electromagnetic induction**:

- **Faraday's law** - the magnitude of induced emf is equal to the rate of change of flux linkage
- **Lenz's law** - the direction of induced current is such as to oppose the motion causing it

To demonstrate **Lenz's law**, you can measure the **speed of a magnet falling through a coil of wire, and its speed when falling from the same height without falling through the coil**. What you will find is that the magnet takes longer to reach the ground when it moves through the coil, this can be explained by Lenz's law:

1. As the magnet approaches the coil, there is a **change of flux through the coil so an emf and a current is induced**.



- Due to Lenz's law, **the direction of induced current is such as to oppose the motion of the magnet** so the **same pole** as the pole of the magnet approaching the coil will be induced in order to repel the magnet. This causes the magnet to slow down, due to electrostatic forces of **repulsion**.
- As the magnet passes through the centre of the coil, there is no change in flux so no emf is induced.
- As the magnet begins to leave the coil, **there is a change in flux, so a current is induced that opposes the motion** of the magnet. Therefore, an **opposite pole** is induced by the magnet causing it to slow down once again, due to electrostatic forces of **attraction**.

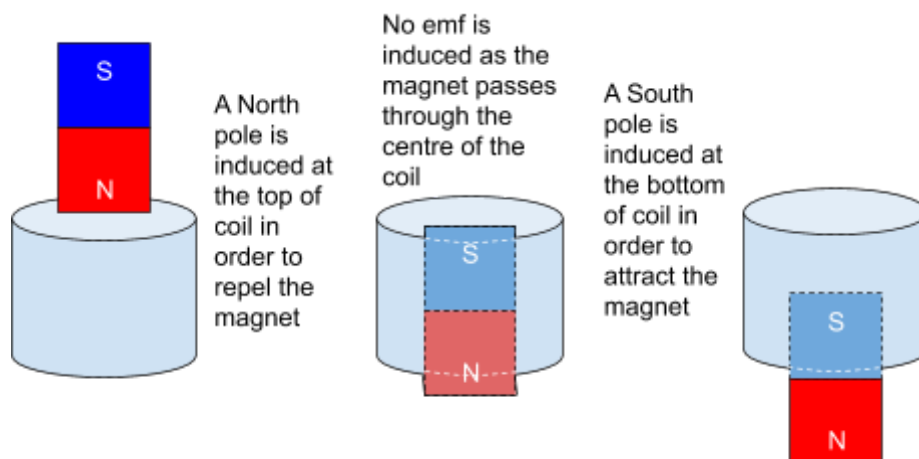

Faraday's law can be expressed in the following equation:

$$\varepsilon = N \frac{\Delta\Phi}{\Delta t}$$

(where ε is magnitude of induced emf, and $N \frac{\Delta\Phi}{\Delta t}$ is rate of change of flux linkage)

You can use the above equation to derive a general formula for the **magnitude of emf induced by a straight conductor** of length l , moving in a magnetic field of flux density B .

The conductor moves at a velocity v , therefore its distance travelled s , will be:

$$s = v\Delta t \quad \text{From this we can find the area if we consider the distance travelled as width.}$$

$$A = lv\Delta t \quad \text{We can use this to find the magnetic flux cut by the conductor.}$$

$$\Delta\Phi = BA = Blv\Delta t$$

Finally, substitute this into the equation for Faraday's law.

$$\varepsilon = \frac{\Delta\Phi}{\Delta t} = \frac{Blv\Delta t}{\Delta t} = Blv \quad \varepsilon = Blv$$

When a **coil rotates at a constant frequency** in a magnetic field, the **emf induced** can be calculated using a formula derived by finding the **derivative of the formula for magnetic flux linkage with respect to time**, as induced emf is equal to the rate of change of flux linkage.



The formula for magnetic flux linkage is $N\Phi = BAN \cos \theta$, however in a rotating coil θ is replaced by ωt , because **flux linkage varies depending on the angular speed of the coil**.

Therefore:

$$N\Phi = BAN \cos(\omega t)$$

$$\varepsilon = BAN\omega \sin(\omega t)$$

Where ω is the angular speed of the coil, and t is the time passed.

3.7.5.5 - Alternating currents

When a coil rotates in a magnetic field an emf is induced. The value of induced emf can be calculated using the formula, $\varepsilon = BAN\omega \sin(\omega t)$, as this contains a sine function, the induced emf is **alternating**, meaning it will change direction with time (shown by the change in sign).

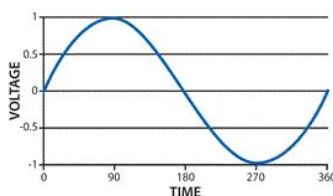
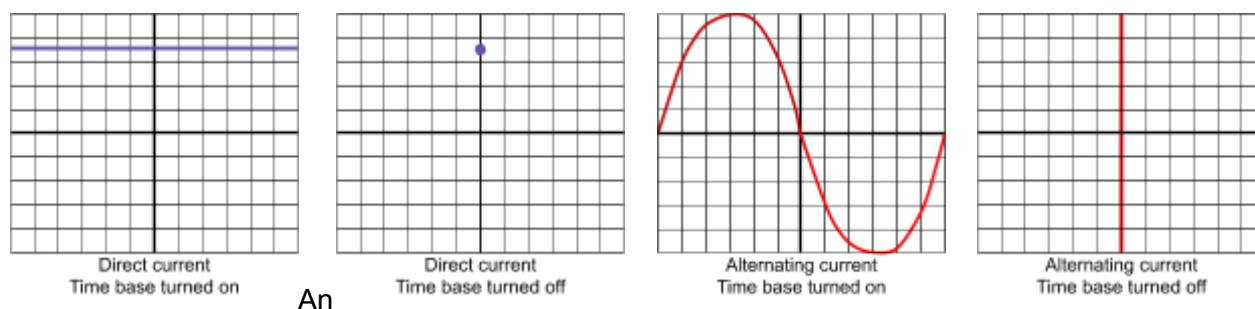

Image source: [NagarjunaReddy.Boggula, CC BY-SA 4.0](#)

Any type of current can be displayed on an **oscilloscope**, which shows the variation of voltage with time, however it is possible to turn off the **time-base**, which will cause the trace to **show all the possible voltages at any time in one area**, this is useful for taking measurements. For a **direct current**, the trace will show a **straight line parallel to the axis**, at the height of the output voltage. If time-base is turned off, then only a dot will be seen on the screen, at the height of the output voltage.

For an **alternating current**, the trace will show a repeating **sinusoidal waveform** which shows the variation of output voltage with time. If the time-base is switched off, then a straight vertical line will appear on the screen, showing all the possible voltages.



oscilloscope will have a fixed grid on its display however, **you can adjust the scale of both axes to make measurements easier**. To change the scale of the Y-axis, you can select the number of volts per division using a **Y-gain control dial**, which will be marked on the oscilloscope. To change



the scale of the X-axis, you can adjust the time **base**, which again will be marked on the oscilloscope.

In order to take measurements from an oscilloscope you will need to count the number of divisions (adjusting the axes to make this easier), and multiply them by either the volts per division or the time base, depending on what you are measuring. The diagram on the right shows the four main things you can measure:

1. **Peak voltage (V_0)** - distance from the equilibrium to the highest (or lowest) point.
2. **Peak-to-peak voltage** - distance from the minimum point to the maximum point.
3. **Root mean square (rms) voltage** - the **average of all the squares of the possible voltages**, this value gives you the **average value of voltage output** by the supply (in either direction). For a sine wave, instead of measuring this directly, you can calculate the value for **rms voltage (V_{rms})** and **rms current (I_{rms})** using the following formulas:

$$I_{rms} = \frac{I_0}{\sqrt{2}} \quad V_{rms} = \frac{V_0}{\sqrt{2}} \quad \text{Where } I_0 \text{ and } V_0 \text{ are peak values of current and voltage.}$$

4. **Time period (T)** - distance from one point on a curve e.g its peak, to the point where the curve repeats, in this example when it reaches the next peak. You can find the frequency of the waveform by using the formula: $f = \frac{1}{T}$.

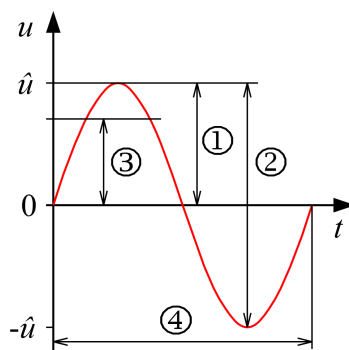

The electricity supplied in homes in the UK is around **230 V**, and is an alternating supply so 230 V is actually the **rms value of voltage**. You can calculate the peak and peak-to-peak voltage of UK mains by knowing the rms value of voltage:

Rearrange the formula $V_{rms} = \frac{V_0}{\sqrt{2}}$, to make peak voltage the subject and calculate V_0 .

$$V_0 = V_{rms} \times \sqrt{2} \quad V_0 = 230 \times \sqrt{2} = \mathbf{330 \text{ V}} \text{ (to 2 s.f.)}$$

Double the value of peak voltage to find peak-to-peak voltage.

$$\text{Peak-to-peak voltage} = 330 \times 2 = \mathbf{660 \text{ V}} \text{ (to 2 s.f.)}$$



3.7.5.6 - The operation of a transformer

Transformers can be used with **alternating currents to change the size of their voltage**. They are made up of a primary coil, which is attached to the input voltage, a secondary coil, which is connected to the output voltage and an iron core. The primary coil provides a changing magnetic field, which passes through the iron core and interacts with the secondary coil, inducing a voltage in the secondary coil.

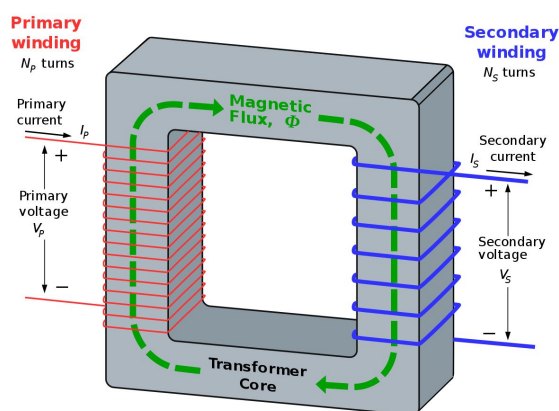

Image source: [BillC at the English Language Wikipedia](#), CC BY-SA 3.0

By using Faraday's law you can deduce that the **ratio of the voltage in the primary coil to the secondary coil, is the same as the ratio of the number of turns on the primary coil to the secondary coil**. This can be written as the equation:

$$\frac{N_s}{N_p} = \frac{V_s}{V_p}$$

Where N_s/N_p is the number of turns on the secondary/primary coil, and V_s/V_p is the voltage in the secondary/primary coil.

There are two types of transformer:

- **Step-up transformer** - increases the input voltage by having more turns on the secondary coil than the primary
- **Step-down transformer** - decreases the input voltage by having less turns on the secondary coil.

You can measure the efficiency of a transformer by finding the ratio between the power output and input into it. As power is the product of current and potential difference, the efficiency of a transformer can be found using the following formula:

$$\text{Transformer efficiency} = \frac{I_s V_s}{I_p V_p}$$

Where I_s/I_p is the current in the secondary/primary coil, and V_s/V_p is the voltage in the secondary/primary coil. You can multiply this value by 100 to get the value of efficiency as a percentage.

One of the main causes of energy loss in a transformer is the production of **eddy currents**, these are induced by the alternating magnetic field in the primary coil, and form a loop. Due to **Lenz's**



law they oppose the field that produced them, reducing field's flux density and they generate heat, which causes energy to be lost. The effects of eddy currents can be reduced by using a **laminated iron core**, meaning that the core is made using layers of iron between layers of an insulator, because the **eddy currents cannot pass through the insulator and so their amplitude is reduced**. Eddy currents can also be reduced by using a core made out of a high resistivity metal.

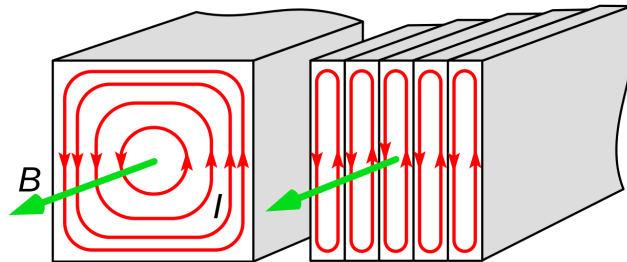

Energy can also be lost due to **resistance in the coils**, as this causes heating. However, this is reduced by using **thick wire**, which has a low resistance. Finally, energy can be lost **if the core is not easily magnetised**, so a magnetically **soft iron core** is used to allow easy magnetisation and demagnetisation.

When transferring electrical power, **the power lost due to resistance is equal to I^2R** , therefore it is vital to reduce the current to a minimum value to prevent unnecessary energy losses.

As **power = current × voltage**, **as the voltage is stepped up, the current will decrease**, so step-up transformers are used when transmitting electricity over long distances.

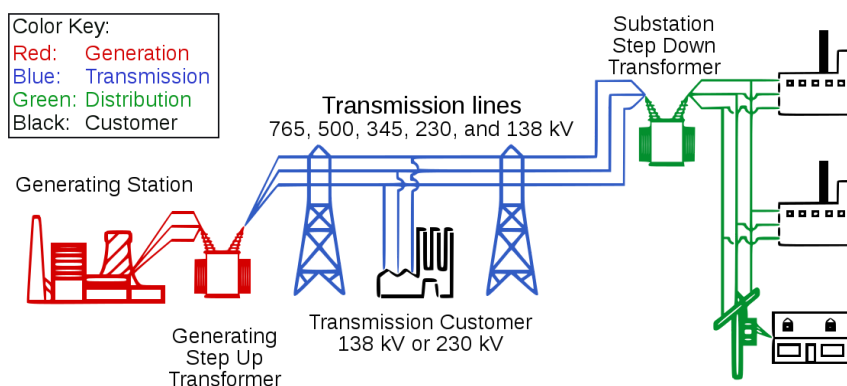

You may need to calculate the power loss when transmitting energy across transmission lines, below are examples of this type of calculation and other calculations using the formulas defined above.



Alternating electric current leaves a power station at 25000 V, and enters the primary coil of a step-up transformer with 50 turns on its primary coil and 750 turns on its secondary coil. Find the output voltage of the transformer.

Use the $\frac{N_s}{N_p} = \frac{V_s}{V_p}$ to find output voltage.

$$V_s = V_p \times \frac{N_s}{N_p} \quad V_s = 25000 \times \frac{750}{50} = 3.75 \times 10^5 \text{ V}$$

500 MW of power is transmitted along 225 km of wire, which has a resistance of 0.2 Ω per kilometre, if the transmission voltage is 3.75×10^5 V, find the power wasted.

Find the total resistance along the whole length of wire.

$$\text{Total resistance} = 225 \times 0.2 = 45 \Omega$$

Find current using $P = VI$.

$$I = \frac{P}{V} \quad I = \frac{500 \times 10^6}{3.75 \times 10^5} = 1330 \text{ A (to 3.s.f)}$$

Finally, calculate energy wasted per second using $P = I^2R$

$$P = 1333.3... \times 45 = 60000 \text{ W}$$

