

© International Baccalaureate Organization 2021

All rights reserved. No part of this product may be reproduced in any form or by any electronic or mechanical means, including information storage and retrieval systems, without the prior written permission from the IB. Additionally, the license tied with this product prohibits use of any selected files or extracts from this product. Use by third parties, including but not limited to publishers, private teachers, tutoring or study services, preparatory schools, vendors operating curriculum mapping services or teacher resource digital platforms and app developers, whether fee-covered or not, is prohibited and is a criminal offense.

More information on how to request written permission in the form of a license can be obtained from <https://ibo.org/become-an-ib-school/ib-publishing/licensing/applying-for-a-license/>.

© Organisation du Baccalauréat International 2021

Tous droits réservés. Aucune partie de ce produit ne peut être reproduite sous quelque forme ni par quelque moyen que ce soit, électronique ou mécanique, y compris des systèmes de stockage et de récupération d'informations, sans l'autorisation écrite préalable de l'IB. De plus, la licence associée à ce produit interdit toute utilisation de tout fichier ou extrait sélectionné dans ce produit. L'utilisation par des tiers, y compris, sans toutefois s'y limiter, des éditeurs, des professeurs particuliers, des services de tutorat ou d'aide aux études, des établissements de préparation à l'enseignement supérieur, des fournisseurs de services de planification des programmes d'études, des gestionnaires de plateformes pédagogiques en ligne, et des développeurs d'applications, moyennant paiement ou non, est interdite et constitue une infraction pénale.

Pour plus d'informations sur la procédure à suivre pour obtenir une autorisation écrite sous la forme d'une licence, rendez-vous à l'adresse <https://ibo.org/become-an-ib-school/ib-publishing/licensing/applying-for-a-license/>.

© Organización del Bachillerato Internacional, 2021

Todos los derechos reservados. No se podrá reproducir ninguna parte de este producto de ninguna forma ni por ningún medio electrónico o mecánico, incluidos los sistemas de almacenamiento y recuperación de información, sin la previa autorización por escrito del IB. Además, la licencia vinculada a este producto prohíbe el uso de todo archivo o fragmento seleccionado de este producto. El uso por parte de terceros —lo que incluye, a título enunciativo, editoriales, profesores particulares, servicios de apoyo académico o ayuda para el estudio, colegios preparatorios, desarrolladores de aplicaciones y entidades que presten servicios de planificación curricular u ofrezcan recursos para docentes mediante plataformas digitales—, ya sea incluido en tasas o no, está prohibido y constituye un delito.

En este enlace encontrará más información sobre cómo solicitar una autorización por escrito en forma de licencia: <https://ibo.org/become-an-ib-school/ib-publishing/licensing/applying-for-a-license/>.

Computer science
Standard level
Paper 1

Tuesday 11 May 2021 (afternoon)

1 hour 30 minutes

Instructions to candidates

- Do not open this examination paper until instructed to do so.
- Section A: answer all questions.
- Section B: answer all questions.
- The maximum mark for this examination paper is **[70 marks]**.

Section A

Answer **all** questions.

1. Identify **two** roles that a computer can perform in a network. [2]
2. Describe **one** method of implementation for a new computer system. [2]
3. Draw the logic circuit represented by the following truth table. [2]

A	B	Z
0	0	1
0	1	0
1	0	0
1	1	1

4. (a) Identify **two** reasons why patches may be necessary for an operating system. [2]
(b) Identify **two** methods that can be used to obtain these patches. [2]
5. Calculate the denary (base 10) equivalent of the hexadecimal number BF. [2]
6. Identify **two** reasons why fibre optic cable would be preferred over wireless connectivity. [2]
7. Distinguish between a *variable* and a *constant*. [2]

8. List the output from the given algorithm for the following input. [3]

2, 6, 8, 9, 12, 15, 18, 20

```
loop for Count from 0 to 7
  input NUMBER
  if NUMBER div 2 = NUMBER / 2 then
    if NUMBER div 3 = NUMBER / 3 then
      output NUMBER
    end if
  end if
end loop
```

9. Define the term *data packet*. [1]

10. Identify **one** common feature found in the user interface of application software to improve its usability. [1]

11. Construct the truth table for the following logic circuit: [4]

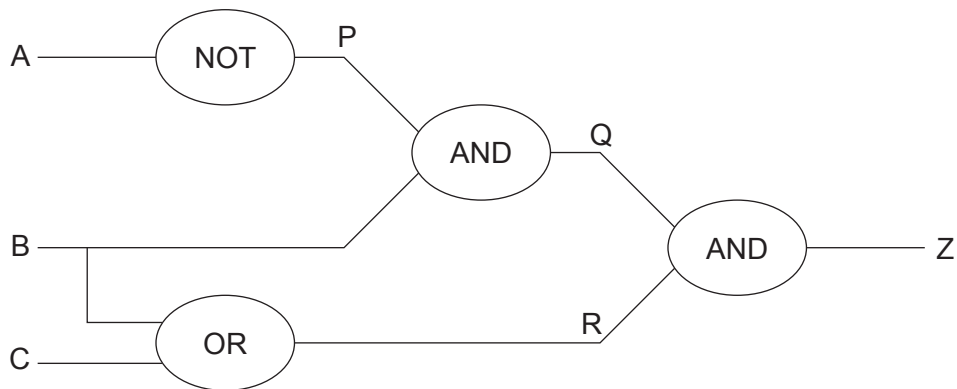

Blank page

Section B

Answer **all** questions.

12. A school currently has a cabled network but wants to add wireless networking across the whole campus.

(a) Describe **two** hardware components the school will need to implement the wireless network. [4]

(b) Identify **two** advantages to the students of the new wireless network. [2]

There are concerns that unauthorized people could access the data on the wireless network.

(c) Outline **two** methods the school could employ to prevent network data from being accessed over their wireless system. [4]

The school has decided to implement a virtual private network (VPN) to provide access to its network.

(d) Identify **two** technologies the school would require to provide a VPN. [2]

(e) Explain **one** benefit to the staff of using a VPN to remotely access the school network. [3]

13. A company has 600 employees whose names are currently stored using a collection called `NAMES`. The names are stored as surname, first name. For example: Smith, Jane, Uysal, Rafael, Ahmed, Ishmael, Jonsonn, Sara, ...

(a) Construct a pseudocode algorithm that will store the surnames in one array and first names in another. [4]

The names in the collection are kept in a random order. However, it would be more useful if they were kept in alphabetical order.

(b) Construct a pseudocode algorithm that will sort the surnames into alphabetical order using the *bubble sort* method. The order of the first names must also be changed so that they keep the same index as their corresponding surname. [5]

The company's staff list is now organized in the arrays in alphabetical order.

A binary search was used to find a specific name in the array.

(c) Describe the process a binary search would follow to find a record in the surname array. [4]

(d) Outline **one** benefit of using sub-programmes to implement your algorithms from parts (a) and (b). [2]

14. The following flowchart represents a standard algorithm:

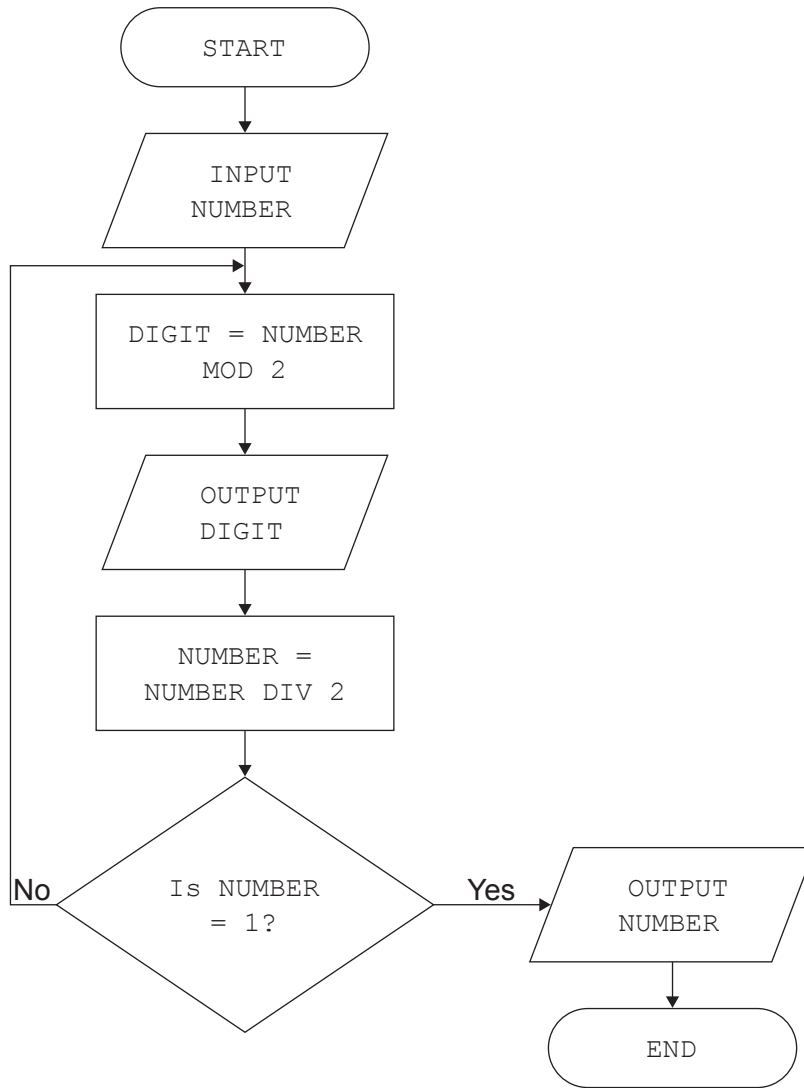

(a) Copy and complete the table that traces the algorithm in the flowchart using an input value of 19. [4]

NUMBER	DIGIT	OUTPUT
19		

(b) State the purpose of the algorithm. [1]

(c) Construct the algorithm from the flowchart using pseudocode. Add additional pseudocode to ensure that input is validated to only allow positive integers to be entered. [6]

(This question continues on the following page)

(Question 14 continued)

Efficiency is an important consideration when designing algorithms to ensure they don't waste computer resources such as memory or processing time.

- (d) Suggest **two** design considerations that could be made to an algorithm that would make it more efficient.

[4]

References: