

Name:

Exam Style Questions

Area of a Segment



Corbettmaths

Equipment needed: Calculator, pen

Guidance

1. Read each question carefully before you begin answering it.
2. Check your answers seem right.
3. Always show your workings

Video Tutorial

www.corbettmaths.com/contents

Video 63



Answers and Video Solutions



1. Shown below is a sector, OAB, of a circle with centre O.

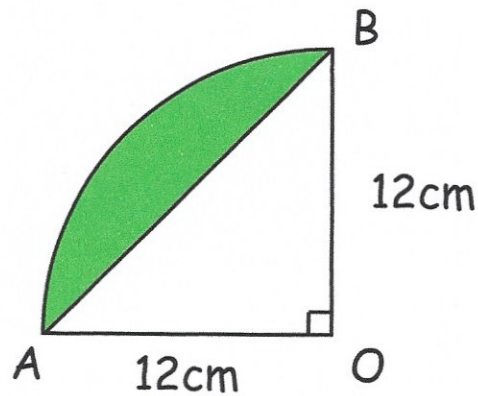

AB is a chord of the circle.

Work out the area of the shaded segment.

$$\text{Sector: } \frac{1}{4} \times \pi \times 12^2 = 36\pi \quad (113.0973355)$$

$$\text{triangle: } \frac{1}{2} \times 12 \times 12 = 72 \text{ cm}^2$$

$$36\pi - 72 = 41.0973\dots$$

$$\begin{array}{r} 41.1 \\ \hline \dots\dots\dots \text{cm}^2 \\ (4) \end{array}$$

2. Shown below is a sector, OAB, of a circle with centre O.

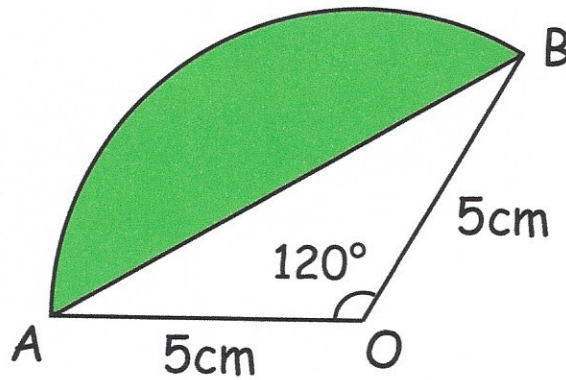

AB is a chord of the circle.

Work out the area of the shaded segment.
Give your answer to 1 decimal place.

$$\text{Sector: } \frac{1}{3} \times \pi \times 5^2 = 26.17993878$$

$$\text{Triangle: } \frac{1}{2} \times 5 \times 5 \times \sin 120 = 10.82531755$$

$$26.17993... - 10.8253... = 15.3546...$$

15.4
.....cm²
(5)

3. The diagram shows a sector of a circle with centre O.
The radius of the circle is 10cm.

ABC is an arc of the circle.
AC is a chord of the circle.
Angle AOC = 30°

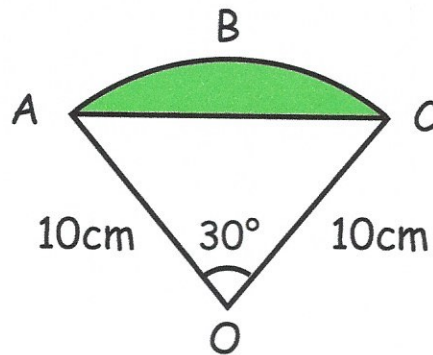

Calculate the area of the shaded segment.

$$\text{Sector} = \frac{30}{360} \times \pi \times 10^2 = 26.1799\dots$$

$$\text{Triangle} = \frac{1}{2} (10)(10) \sin 30 = 25$$

$$26.1799\dots - 25 = 1.1799\dots$$

1.18

.....cm²
(5)

4.

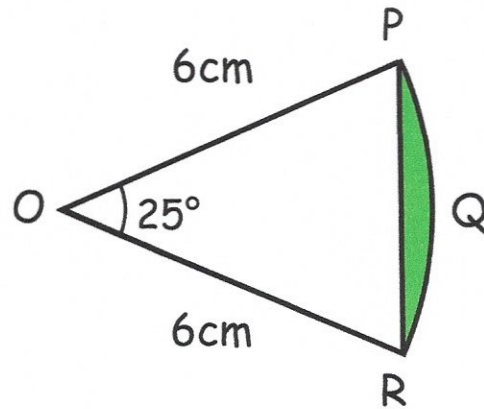

PQR is an arc of a circle centre O with radius 6cm.
PR is a chord of the circle.
Angle POR = 25°.

Calculate the area of the shaded region.
Give your answer to 4 significant figures.

$$\text{Sector} = \frac{25}{360} \times \pi \times 6^2 = 7.85398\dots$$

$$\text{triangle} = \frac{1}{2} (6)(6) \sin 25 = 7.607128711\dots$$

$$7.85398\dots - 7.607128711\dots = 0.2468529\dots$$

$$\begin{array}{r} 0.2469 \\ \hline \end{array} \text{cm}^2$$

(5)

5. BC is a chord of a circle, centre O, radius 9cm.
BC = 10cm.

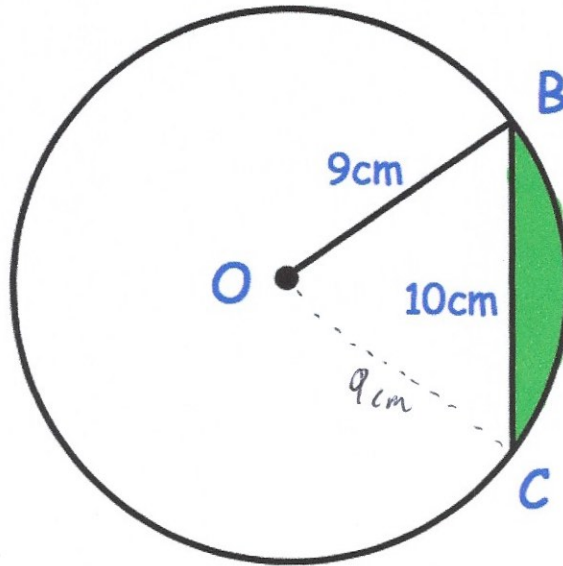

Calculate the area of the shaded segment.

$$\cos \theta = \frac{9^2 + 9^2 - 10^2}{2 \times 9 \times 9}$$

$$\cos \theta = 0.3827\dots$$

$$\theta = 67.4979\dots$$

$$\theta = 67.498^\circ$$

$$\text{Sector} = \frac{67.498}{360} \times \pi \times 9^2 = 47.71150859$$

$$\text{triangle} = \frac{1}{2} (9) (9) \sin 67.498 = 37.41657\dots$$

$$47.7115\dots - 37.4165\dots = 10.2949\dots$$

$$\underline{\underline{10.295}} \text{ cm}^2$$

(6)

6. The diagram shows a triangle OAB and the arc AB of a circle whose centre is O and whose radius is 20cm.

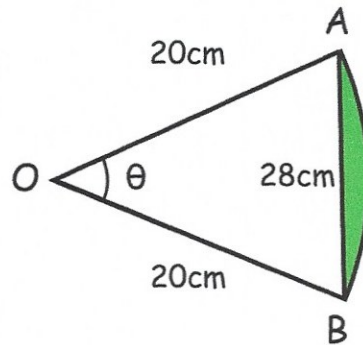

- (a) Find the size of the angle θ .

$$\cos \theta = \frac{20^2 + 20^2 - 28^2}{2 \times 20 \times 20}$$

$$\cos \theta = \frac{1}{50}$$

$$\theta = 88.854^\circ$$

$$\underline{\underline{88.854^\circ}} \quad (3)$$

- (b) Find the length of the arc AB.

$$\frac{88.854}{360} \times \pi \times 40 = 31.015899\dots$$

$$\underline{\underline{31.016}} \text{ cm} \quad (3)$$

- (c) Find the area of the shaded segment to the nearest cm^2 .

$$\text{Sector} : \frac{88.854}{360} \times \pi \times 20^2 = 310.1589986$$

$$\text{triangle} : \frac{1}{2} (20)(20) \sin 88.854 = 199.959996$$

$$\underline{\underline{110}} \text{ cm}^2 \quad (3)$$

$$310.1589986 - 199.959996 = 110.199\dots$$

7. OAB is a sector of a circle, centre O.
OA is 9cm and arc AB is 10cm

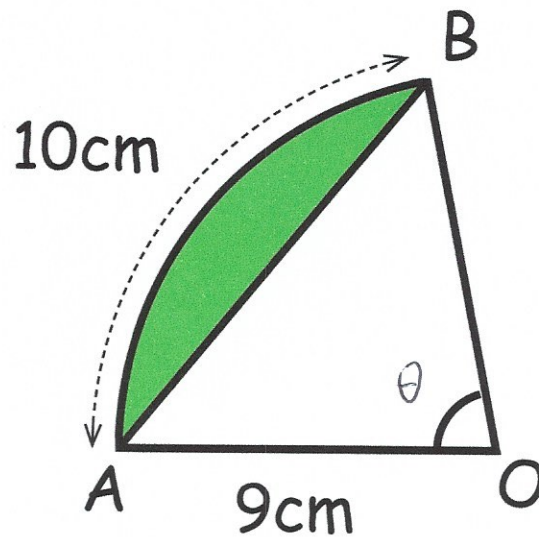

- (a) Find the size of the angle AOB.

$$\frac{\theta}{360} \times \pi \times 18 = 10$$

$$\theta \times \pi \times 18 = 3600$$

$$\theta \times \pi = 200$$

$$\theta = 63.6619\dots$$

$$\underline{\underline{63.662}} \text{ } ^\circ$$

(3)

- (b) Find the area of the shaded segment.

$$\text{Sector} : \frac{63.6619\dots}{360} \times \pi \times 9^2 = 45$$

$$\text{Triangle} : \frac{1}{2} (9) (9) \sin 63.6619\dots = 36.29578\dots$$

$$45 - 36.29578\dots$$

$$\underline{\underline{8.704}} \text{ cm}^2$$

(3)

8. Shown below are two circles, with centres A and B.
The radius of each circle is 9cm.

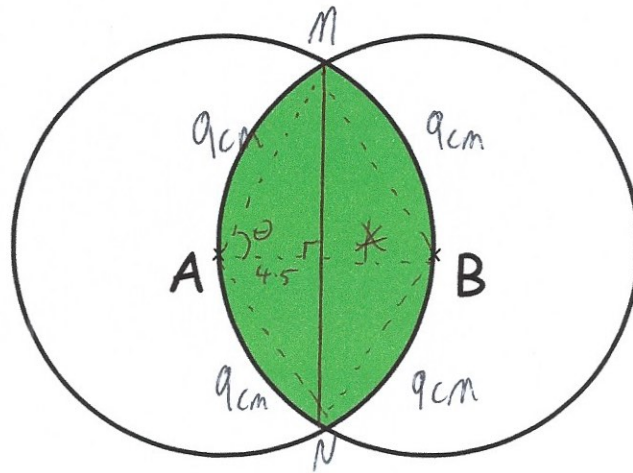

$$\cos \theta = \frac{4.5}{9}$$

$$\theta = 60^\circ$$

$$\angle NAM = 120^\circ$$

AB = 9cm

Work out the area of the shaded region.

Area of segment *

$$\text{Sector AMN} : \frac{120}{360} \times \pi \times 9^2 = 27\pi \text{ cm}^2$$

$$\text{Triangle AMN} : \frac{1}{2} (9)(9) \sin 120 = 35.07402... \text{ cm}^2$$

$$27\pi - 35.07402... = 49.7489...$$

$$49.7489... \times 2 = 99.498$$

$$\underline{\quad\quad\quad 99.498 \quad\quad\quad} \text{cm}^2$$

(5)