

Name:

Exam Style Questions

Area of a semicircle

Area of a quarter circle



Corbettmaths

Equipment needed: Calculator, pen

Guidance

1. Read each question carefully before you begin answering it.
2. Check your answers seem right.
3. Always show your workings

Video Tutorial

www.corbettmaths.com/contents

Videos 47, 47a



Answers and Video Solutions



1. Shown is a semi-circle.

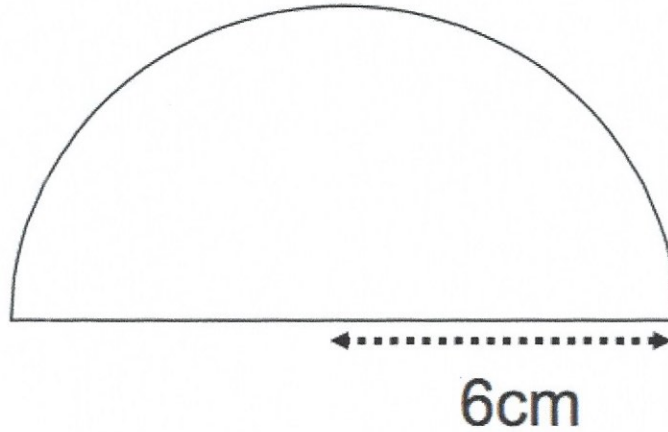

Work out the area.
State the units for your answer.

$$\pi \times 6^2 = 113.0973355 \quad (36\pi)$$
$$113.09733\dots \div 2 = 56.54866\dots \quad (18\pi)$$

$$\begin{array}{r} 56.55 \text{ cm}^2 \\ \hline \end{array} \quad \begin{array}{l} \text{to} \\ 2 \text{ decimal} \\ \text{places.} \end{array}$$

(3)

2. Shown is a semi-circle.

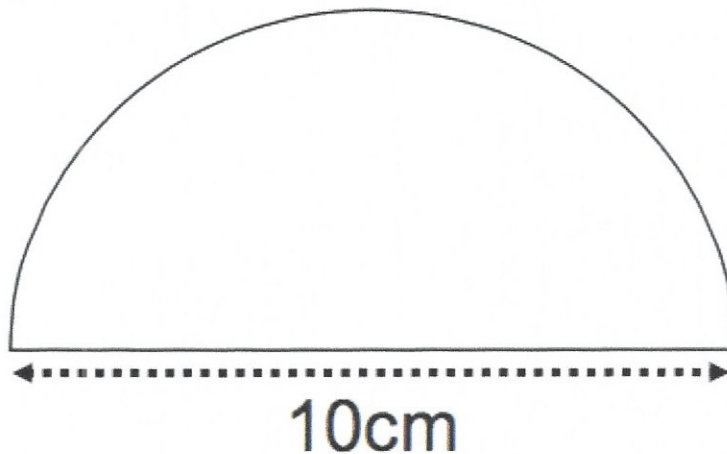

Work out the area.
Give your answer to 1 decimal place.

$$\pi \times 5^2 = 78.5398\dots \quad (25\pi)$$
$$78.539\dots \div 2 = 39.2699\dots \quad (12.5\pi)$$

$$\begin{array}{r} 39.3 \\ \hline \end{array} \text{ cm}^2$$

(3)

3. Below is a semi-circle.

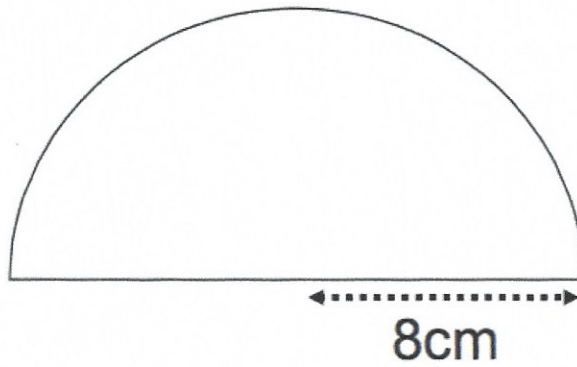

Work out the area of the semi-circle.
Leave your answer in terms of π

$$\pi \times 8^2 = 64\pi$$
$$64\pi \div 2 = 32\pi$$

$$\dots\dots\dots 32\pi \dots\dots\dots \text{cm}^2$$

(3)

4. Shown below is a quarter-circle with a radius of 4.6 cm

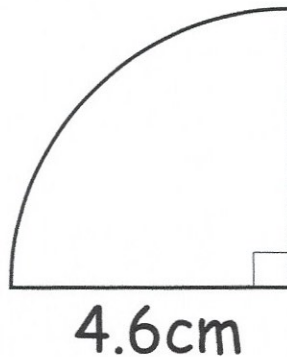

Work out the area.
Give your answer to 1 decimal place.

$$\pi \times 4.6^2 = 66.4761005\dots$$
$$66.4761\dots \div 4 = 16.619\dots$$

$$\dots\dots\dots 16.6 \dots\dots\dots \text{cm}^2$$

(3)

5. Shown below is a quarter-circle with radius 20km.

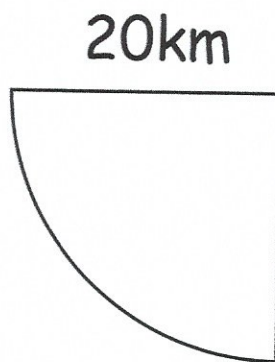

Work out the area of the quarter-circle.
Leave your answer in terms of π

$$\pi \times 20^2 = 400\pi$$

$$400\pi \div 4 = 100\pi$$

$$\dots\dots\dots 100\pi \dots\dots \text{km}^2$$

(3)

6. The semi-circle below has an area of 40cm^2

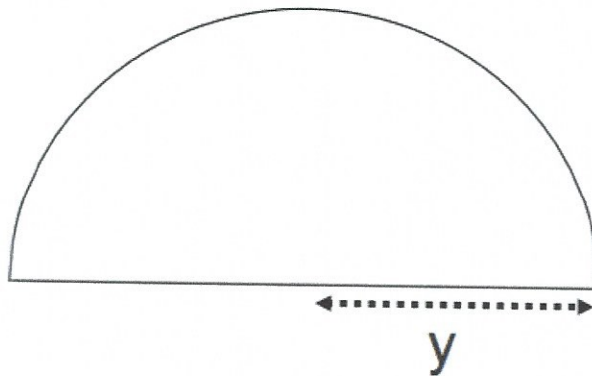

Calculate y .

$$40 \times 2 = 80$$

$$\pi y^2 = 80$$

$$y^2 = 25.46479\dots$$

$$y = 5.046\dots$$

$$\dots\dots\dots 5.05 \dots\dots \text{cm}$$

to 2dp. (3)

7. The semi-circle below has an area of $50\pi \text{ cm}^2$

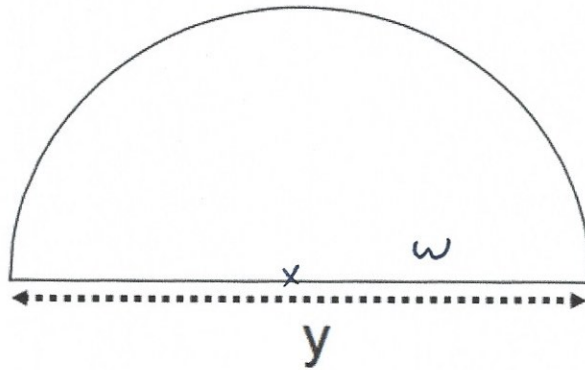

Calculate y .

$$\begin{aligned} \pi w^2 &= 100\pi \\ w^2 &= 100 \\ w &= 10 \\ y &= 20 \end{aligned}$$

$$\begin{aligned} 50\pi \times 2 &= 100\pi \\ \pi y^2 &= 100\pi \\ y^2 &= 100 \\ y &= 10 \end{aligned}$$

.....cm
(3)

8. The quarter circle below has an area of 10.75 cm^2

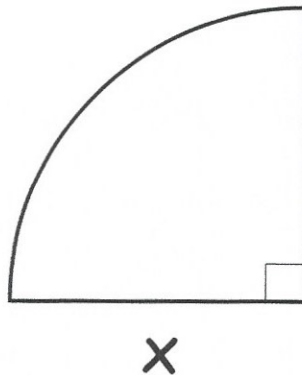

$$10.75 \times 4 = 43$$

Calculate x .

$$\begin{aligned} \pi x^2 &= 43 \\ x^2 &= 13.687... \\ x &= 3.6996... \end{aligned}$$

.....cm
(3)

9. Shown below is a compound shape made from a rectangle and semi-circle.

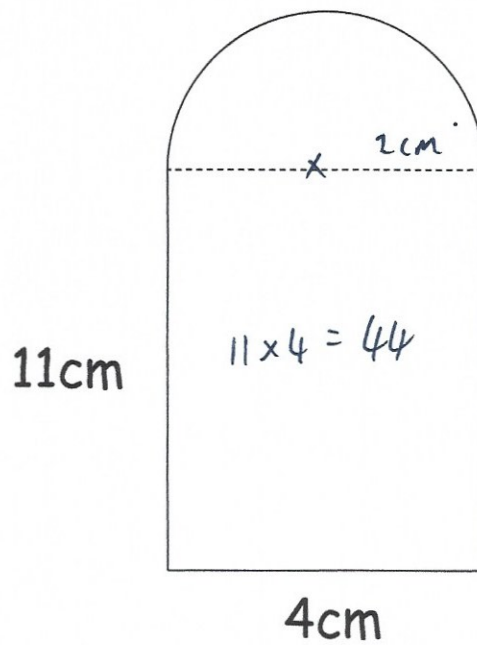

Calculate the area of the shape.

$$\text{rectangle} : 11 \times 4 = 44 \text{ cm}^2$$

$$\text{Semi-circle} : \pi \times 2^2 = 4\pi \quad (\text{or } 12.566\dots)$$

$$4\pi \div 2 = 2\pi \quad (\text{or } 6.28318\dots)$$

or 6.2831...

$$\begin{array}{r} \downarrow \\ 44 + 2\pi = 50.283\dots \end{array}$$

$$\begin{array}{r} 50.283 \\ \hline \text{cm}^2 \\ (3) \end{array}$$

10. The side of a wooden shed is shown below.
The wall is 7 metres long and 4.5 metres tall.
There is a semi-circular glass window, 3m wide.

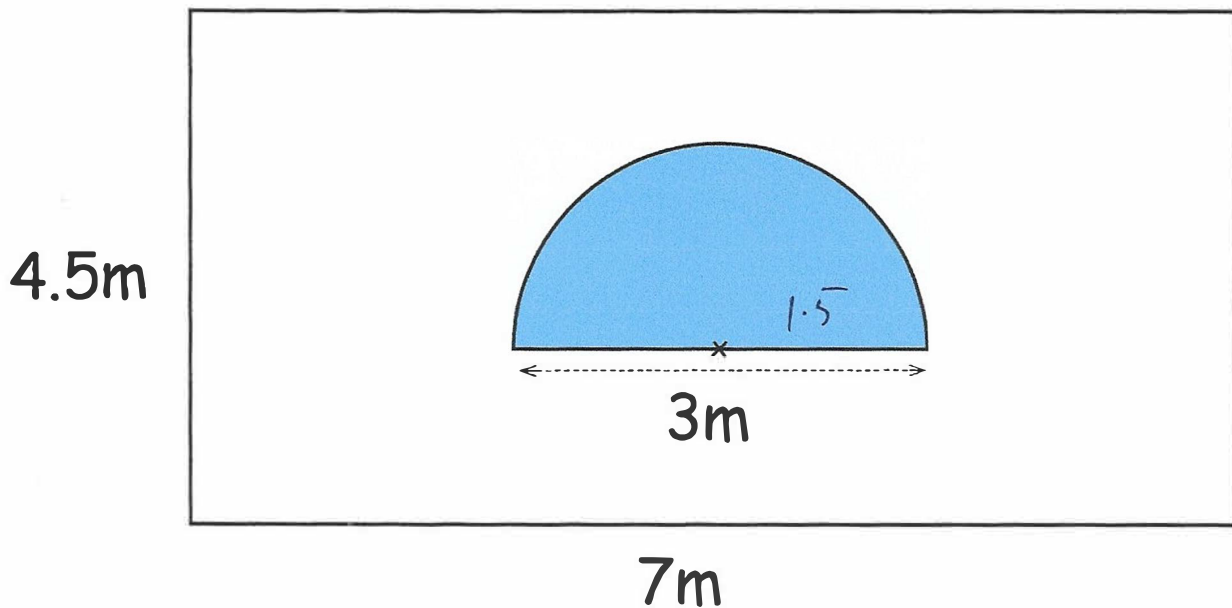

James wants to paint the shed wall.
Each tin costs £7.99 and covers 4m²

- Work out the total cost to paint the shed wall.

$$4.5 \times 7 = 31.5 \text{ m}^2$$

$$\pi \times 1.5^2 = 7.0685\dots$$

$$7.0685\dots \div 2 = 3.534\dots \text{ m}^2$$

$$31.5 - 3.534\dots = 27.96570826 \text{ m}^2$$

$$27.9657\dots \div 4 = 6.991\dots$$

7 tins needed

$$7 \times 7.99 = \text{£}55.93$$

55.93
£.....
(5)

11. A goat is in a square field which has length 12m.
The goat is tied to the middle of a 12m fence on one side with a 5m rope.

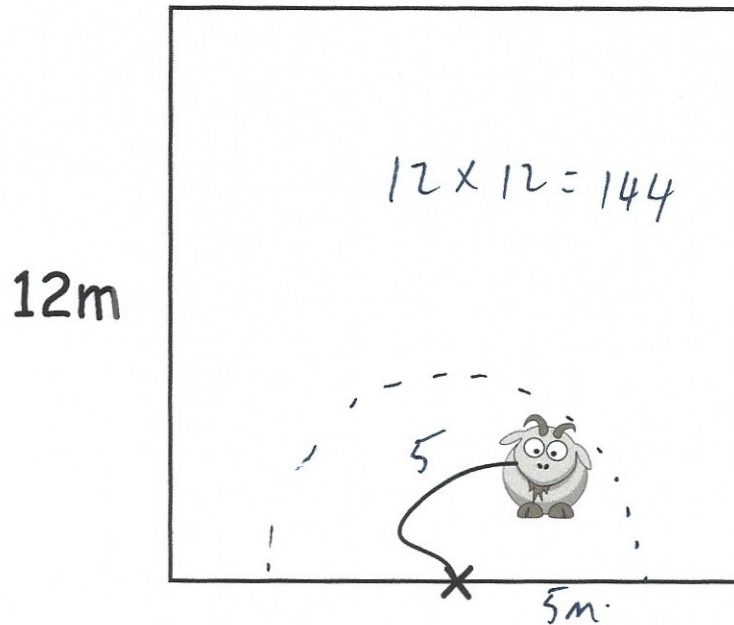

Work out the percentage of the field the goat can reach.

$$\pi \times 5^2 = 78.5398\dots$$

$$78.5398\dots \div 2 = 39.2699\dots$$

$$\frac{39.2699\dots}{144} \times 100 = 27.27\dots$$

$$\frac{27.27}{\dots\dots\dots} \%$$

(5)

12. Shown below is a running track at a local leisure centre.

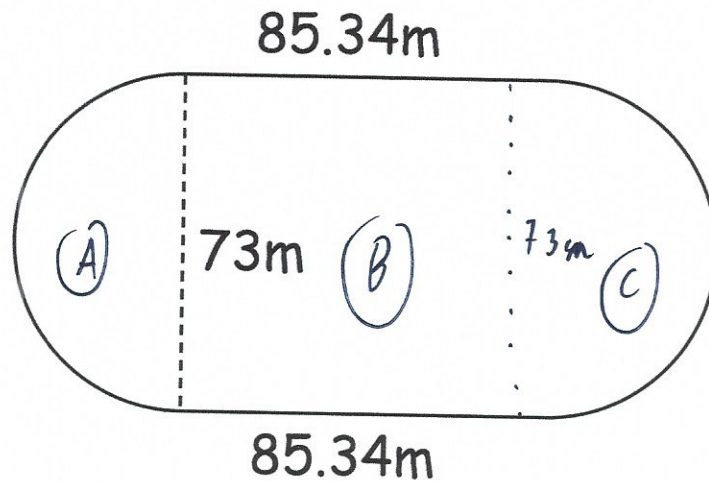

$$73 \div 2 = 36.5$$

Calculate the area inside the running track.

$$(A) \quad \pi \times 36.5^2 = 4185.386\dots$$

$$4185.386\dots \div 2 = 2092.693\dots \text{ m}^2$$

$$(C) \quad 2092.693\dots \text{ m}^2$$

$$(B) \quad 73 \times 85.34 = 6229.82 \text{ m}^2$$

$$2092.693\dots + 6229.82 + 2092.693\dots = 10415.20681$$

$$\begin{array}{r} 10415.2 \\ \hline \dots\dots\dots \text{ m}^2 \\ (4) \end{array}$$

13.

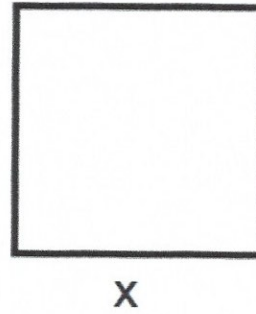
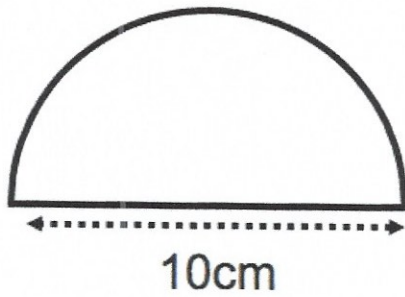

The semi-circle and square have the same area.

Calculate the side length of the square.

$$\pi \times 5^2 = 78.5398\dots$$

$$78.5398\dots \div 2 = 39.2699\dots$$

$$\sqrt{39.2699\dots} = 6.2665\dots$$

$$\begin{array}{r} 6.267 \\ \hline \dots\dots\dots\text{cm} \\ \text{to 3 dp.} \end{array} \quad \begin{array}{l} (4) \end{array}$$

14. A shape is made from one large semicircle and three small congruent semicircle.

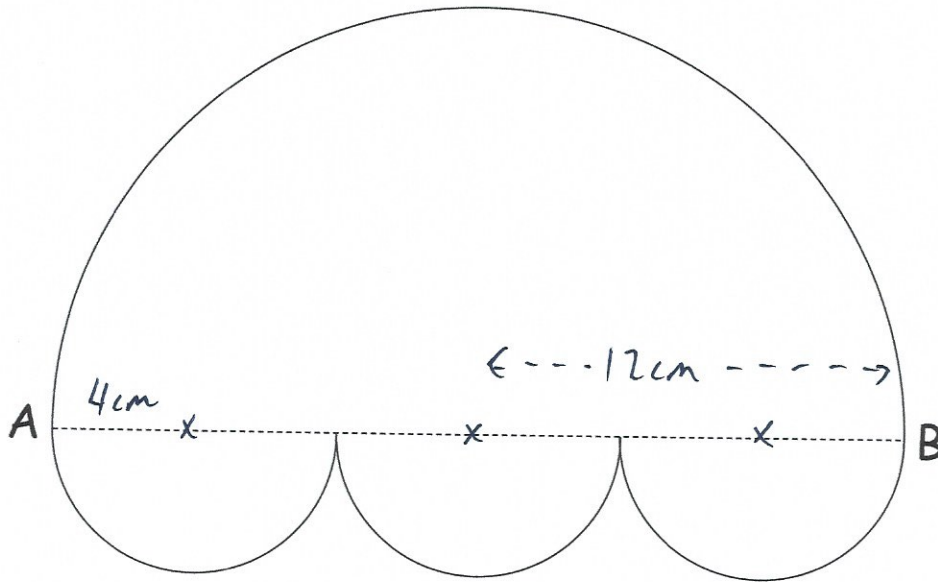

$$AB = 24\text{cm}$$

Work out the area of the shape.

$$\pi \times 4^2 = 50.265\dots (16\pi)$$

$$16\pi \div 2 = 8\pi \quad (25.1327\dots)$$

$$\pi \times 12^2 = 144\pi \quad (452.389\dots)$$

$$144\pi \div 2 = 72\pi \quad (226.194\dots)$$

$$72\pi + 8\pi + 8\pi + 8\pi = 96\pi$$

$$301.59\dots$$

$$\frac{301.6}{\dots} \text{cm}^2$$

(4)
to 1 dp.

15. Farmer Kennedy is planting a crop in her field.



The field, ABCD, consists of a triangle and a quarter-circle.

D is the midpoint of AC.

DC = 30m

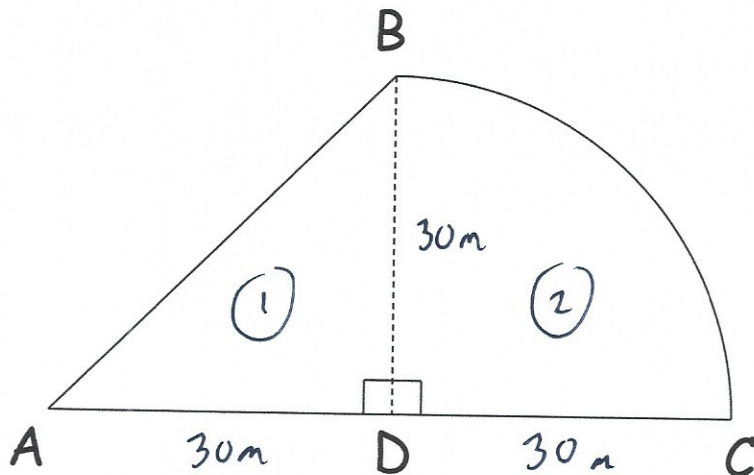

The seed costs £1.50 per square metre.

When fully grown, Farmer Kennedy can sell the crop from 4m² for £50

Calculate the profit she should make.

$$(1) \quad \frac{1}{2} \times 30 \times 30 = 450 \text{ m}^2$$

$$(2) \quad \pi \times 30^2 = 900\pi$$
$$900\pi \div 4 = 225\pi \quad (706.858\dots)$$

$$450 + 706.858\dots = 1156.858\dots \text{ m}^2$$

$$1156.858\dots \times 1.50 = \pounds 1735.29 \quad (\text{cost})$$

$$50 \div 4 = \pounds 12.50 \text{ per m}^2 \quad (\text{selling price per m}^2)$$

$$1156.858\dots \times 12.5 = \pounds 14460.73 \quad (\text{sold for})$$

$$\begin{array}{r} \pounds 12725.44 \\ \hline \end{array} \quad (6)$$

$$14460.73 - 1735.29$$
$$= 12725.44$$

16. Below is a quarter-circle with centre O and radius 6cm

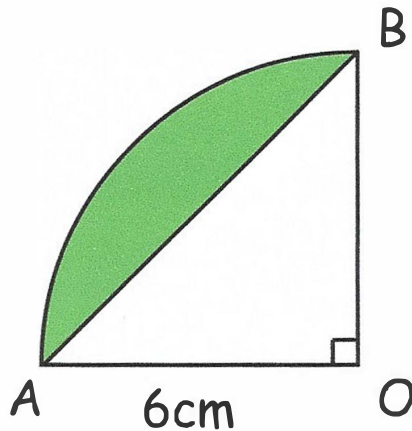

(a) Find the area of quarter-circle OAB.

$$\pi \times 6^2 = 36\pi$$

$$36\pi \div 4 = 9\pi \text{ cm}^2$$

$$28.274\dots$$

$$\begin{array}{r} 28.274 \\ \dots\dots\dots \text{cm}^2 \\ (3) \end{array}$$

(b) Find the area of the shaded segment.

$$\Delta OAB \quad \frac{1}{2} \times 6 \times 6 = 18 \text{ cm}^2$$

$$28.27433\dots - 18 = 10.274\dots$$

$$\begin{array}{r} 10.274 \\ \dots\dots\dots \text{cm}^2 \\ (3) \end{array}$$

17. Nihal designs a logo.
 He has drawn two semicircles, one with base AC and another with base AB.

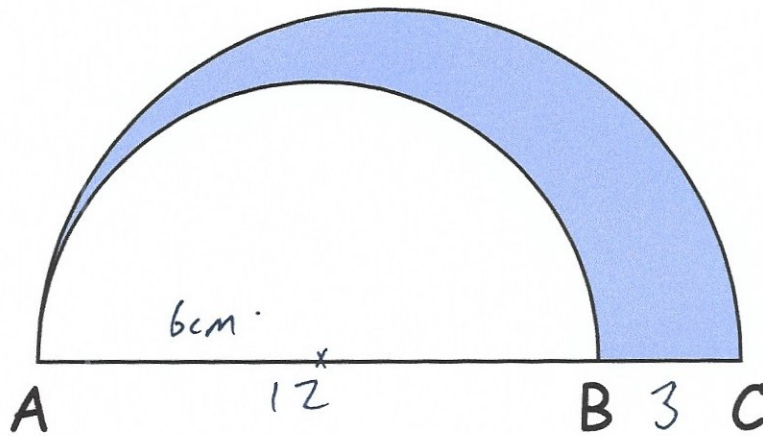

B is a point on the line AC such that $AB : AC = 4 : 5$

$BC = 3\text{cm}$.

Find the area of the shaded region.

$$\begin{aligned} 3 \times 4 &= 12 \\ AB &= 12\text{cm} \\ AC &= 15\text{cm} \\ BC &= 3\text{cm} \end{aligned}$$

$$\pi \times 6^2 = 36\pi \quad (113.09\dots)$$

$$36\pi \div 2 = 18\pi \quad (56.548\dots)$$

$$\pi \times 7.5^2 = 56.25\pi \quad (176.714\dots)$$

$$56.25\pi \div 2 = 28.125\pi \quad (88.357\dots)$$

$$88.357\dots - 56.548\dots = 31.808\dots \text{cm}^2$$

(or 10.125π)

$$\begin{array}{r} 31.8086 \text{ cm}^2 \\ \hline \end{array} \quad (5)$$