

# Circumference

Video 60 on [www.corbettmaths.com](http://www.corbettmaths.com)

Examples



Click here



Scan here

Workout

Question 1: Calculate the circumference of the following circles.  
Give your answers to 1 decimal place.

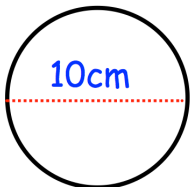
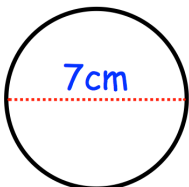
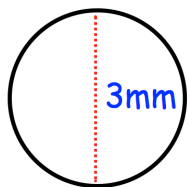
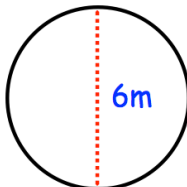
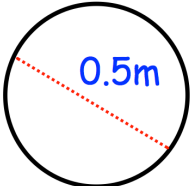
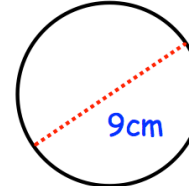
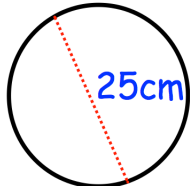
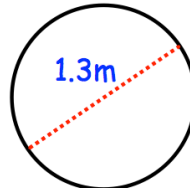
- |  |  |   |  |
|--|--|---|--|
| (a)   | (b)   | (c)   | (d)   |
| (e)  | (f)  | (g)  | (h)  |

Question 2: Calculate the circumference of the following circles.  
Give your answers to 1 decimal place.

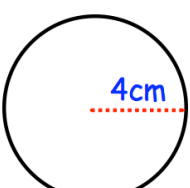
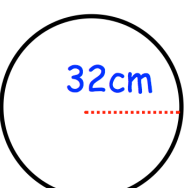
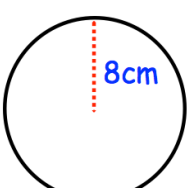
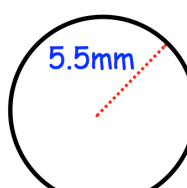
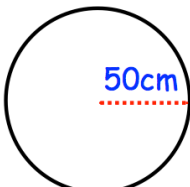
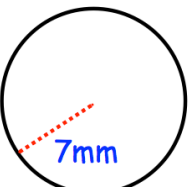
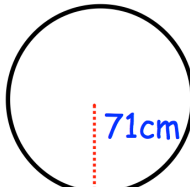
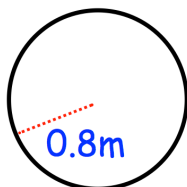
- |   |   |  |   |
|---|---|--|---|
| (a)  | (b)  | (c)  | (d)  |
| (e)  | (f)  | (g)  | (h)  |

Question 3: Work out the circumference of the following circles.  
Give your answers to 1 decimal place.

- |                                |                                      |
|--------------------------------|--------------------------------------|
| (a) A circle with diameter 2cm | (d) A circle with radius 0.15km      |
| (b) A circle with diameter 14m | (e) A circle with diameter 90 inches |
| (c) A circle with radius 3cm   | (f) A circle with radius 5.7 yards   |

# Circumference

Video 60 on [www.corbettmaths.com](http://www.corbettmaths.com)

Question 4: Calculate the circumference of the following circles.  
Give your answers to 1 decimal place.

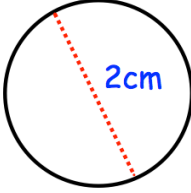
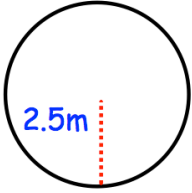
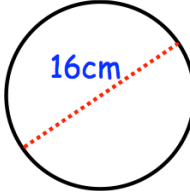
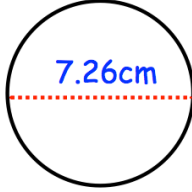
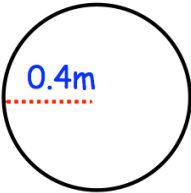
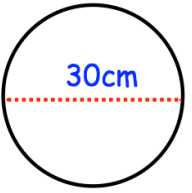
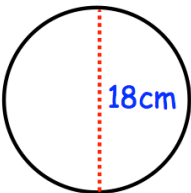
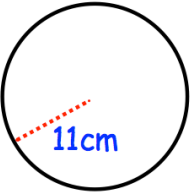
(a) 	(b) 	(c) 	(d) 
(e) 	(f) 	(g) 	(h) 

Question 5: Calculate the circumference of the following circles.  
Leave your answer in terms of  $\pi$

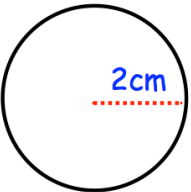
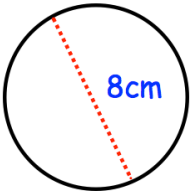
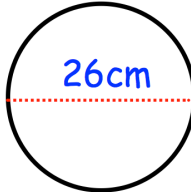
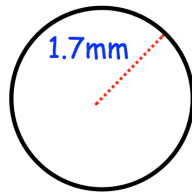
(a) 	(b) 	(c) 	(d) 
---	---	--	---

Question 6: Work out the circumference of the following circles.  
Leave your answer in terms of  $\pi$

- (a) A circle with diameter 12cm
- (b) A circle with diameter 52cm
- (c) A circle with radius 10cm
- (d) A circle with diameter 3cm
- (e) A circle with radius 4km

Question 7: Find the size of the diameter for each of the following circles.  
Give your answer to 2 decimal places.

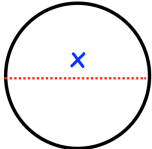
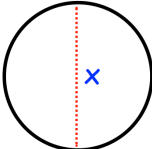
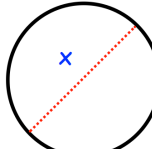
(a) <span style="color: green;">Circumference = 12cm</span> 	(b) <span style="color: green;">Circumference = 50cm</span> 	(c) <span style="color: green;">Circumference = 3m</span> 
--	--	--

# Circumference

Video 60 on [www.corbettmaths.com](http://www.corbettmaths.com)

Question 8: Find the size of the radius for each of the following circles.  
Give your answer to 2 decimal places.

(a)

Circumference = 80cm

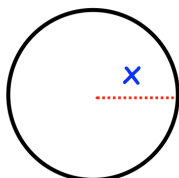

(b)

Circumference = 42m

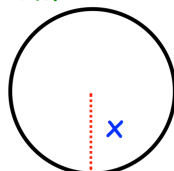

(c)

Circumference = 2m

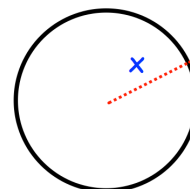

## Apply

Question 1: A circular table top has a diameter of 85cm. Work out the circumference of the table top.

Question 2: A pizza has a circumference of 50cm. Work out the diameter of the pizza.



Question 3: A bicycle wheel has a diameter of 62cm. The wheel makes 80 complete revolutions.  
How far has the bicycle travelled?  
Give your answer in metres.



Question 4: Which shape has the greatest perimeter?

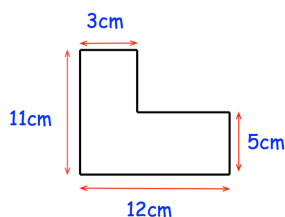

Shape A

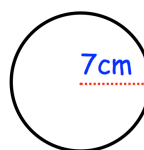

Shape B

Question 5: The circle and the square have the same perimeter.  
Calculate the value of  $x$ .

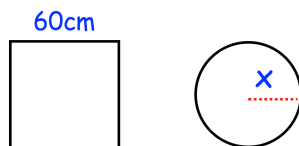

Question 6: A wheel has a diameter of 15cm.  
The wheel travels 50 metres.  
How many complete revolutions does the wheel complete?

Question 7: Calculate the perimeter of the pink shape.

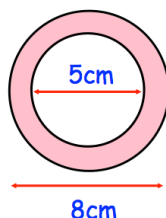

Question 8: Nicole is a wedding organiser.  
The guests are to sit at circular tables with a diameter of 180cm.  
Each guest needs 70cm around the circumference of the table.  
There are 18 tables at the venue.  
A total of 145 guests are attending the wedding.  
Are there enough tables?

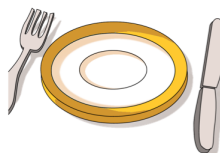

Question 9: The area of a circle is 40cm.  
Calculate the circumference of the circle.

Question 10: The circumference of a circle is 1m.  
Calculate the area of the circle.

Answers

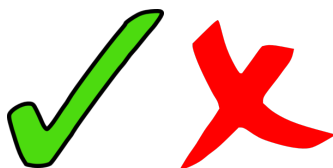

Click here



Scan here