

Name:

Exam Style Questions

# Density



Corbettmaths

Equipment needed: Calculator, pen

## Guidance

1. Read each question carefully before you begin answering it.
2. Check your answers seem right.
3. Always show your workings

Video Tutorial

[www.corbettmaths.com/contents](http://www.corbettmaths.com/contents)

# Video 384



Answers and Video Solutions



1. A piece of wood has a mass of 8g and a volume of 10cm<sup>3</sup>.  
Work out the density of the wood.



.....g/cm<sup>3</sup>  
(2)

---

2. What is the volume of a piece of metal that has a mass of 300g and density of 6g/cm<sup>3</sup>?



.....cm<sup>3</sup>  
(2)

---

3. A piece of plastic has a density of 1.3g/cm<sup>3</sup> and a volume of 100cm<sup>3</sup>.  
Work out the mass of the piece of plastic.



.....g  
(2)

---

4. Iron has a density of 7.8g/cm<sup>3</sup>.  
A solid iron statue has a mass of 877.5g.  
Work out the volume of the statue.



.....cm<sup>3</sup>  
(2)

5.  A solid silver spoon has a mass of 65.1g.  
The volume of the spoon is 6.2cm<sup>3</sup>.  
Calculate the density of silver.

.....g/cm<sup>3</sup>  
**(2)**

---

6.  A glass cube of side length 5cm has a mass of 306.25g.  
Calculate the density of the glass.

.....g/cm<sup>3</sup>  
**(3)**

---

7.  A liquid has mass of 10kg and a density of 1.18g/cm<sup>3</sup>.  
Calculate the volume of the liquid.  
Include suitable units.

.....  
**(3)**

---

8.  A garden ornament has a volume of 0.05m<sup>3</sup>.  
The ornament is made from a stone that has a density of 6.4g/cm<sup>3</sup>.  
Calculate the mass of the ornament.  
Include suitable units.

.....  
**(3)**

9. The mass of  $3\text{m}^3$  of tin is 21840kg.



(a) Work out the density of tin.

..... $\text{kg}/\text{m}^3$   
(2)

The density of aluminium is  $2712\text{kg}/\text{m}^3$ .

(b) Work out the difference in mass between  $5\text{m}^3$  of tin and  $5\text{m}^3$  of aluminium.

.....kg  
(3)

---

10. Mr.Dixon is building a toy boat for his son.



He has three different planks of wood to choose from.

Plank A	Plank B	Plank C
Volume = $750\text{cm}^3$ Mass = 900g	Volume = $0.0152\text{m}^3$ Mass = 7.6kg	Volume = $1000\text{cm}^3$ Mass = 1.02kg

If wood has a density under  $1\text{g}/\text{cm}^3$ , it will float.

Which plank of wood is the most suitable?

Explain your answer.

Plank .....  
(4)

11. The diagram below shows a solid block of ice.

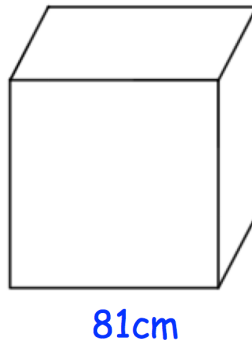

A block of ice weighs  $\frac{1}{2}$  tonne.  
The block is a cube with side length 81cm.

Find the density of the ice.  
Give your answer in kilograms per cubic metre.

.....kg/m<sup>3</sup>  
**(3)**

12. The diagram shows a solid cylinder.

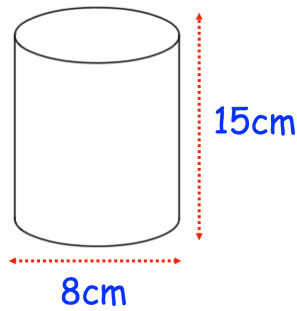

The cylinder is made from titanium.  
The density of titanium is 4.43g/cm<sup>3</sup>

Calculate the mass of the cylinder.

.....g  
**(3)**

13. The diagram shows a solid triangular prism.

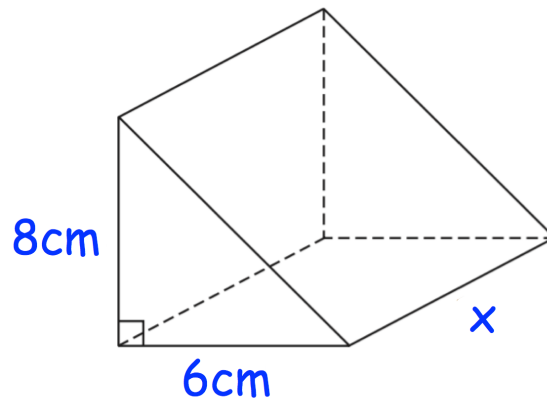

The prism is made from wood and has a mass of 643.8g  
The density of wood is 1.85g/cm<sup>3</sup>

Calculate the length of the prism.

.....cm  
(4)

14. Material A has a density of 5.8g/cm<sup>3</sup>  
Material B has a density of 4.1g/cm<sup>3</sup>



377g of Material A and 1.64kg of Material B form Material C.

Work out the density of Material C.

.....g/cm<sup>3</sup>  
(4)

15. Liquid A and liquid B are mixed in the ratio of volumes, 2 : 5 to make liquid C.



Liquid A has a density of  $1.25\text{g/cm}^3$

Liquid B has a density of  $0.98\text{g/cm}^3$

Work out the density of liquid C.

..... $\text{g/cm}^3$

**(3)**

16. Winston has two blocks, A and B, each made from a different metal.



The density of the metal used to make block A is twice the density of the metal used to make block B.

The mass of block A is six times of the mass of block B.

Complete the sentence.

The volume of block A is \_\_\_\_\_ times the volume of block B.

**(1)**

17. Isabella is loading granite tiles into her trailer, that can carry up to 600kg.



Each tile measures 30cm by 30cm by 2.5cm  
The density of the granite is  $2.7\text{g/cm}^3$

Isabella says that she can placed 100 tiles in the trailer.

Is she correct?

Explain your answer.

.....

.....

.....

**(5)**

18. The diagram shows a solid glass paperweight.

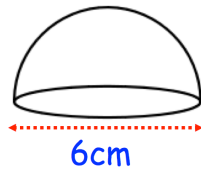

The paperweight is a hemisphere with diameter 6cm.  
The glass has a density of  $3\text{g/cm}^3$ .

Calculate the mass of the paperweight.

.....g  
(4)

19. A solid metal sphere has a radius of 4cm, correct to the nearest centimetre.  
Mass of the sphere is 720g, correct to two significant figures.



Work out the greatest possible density of the metal.  
Give your answer to three significant figures.

.....g/cm<sup>3</sup>  
(4)

20. The diagram below shows a solid cone.

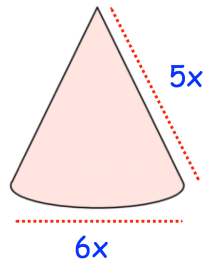

The cone is made from a material with density  $5\text{g/cm}^3$ .

Write an expression for the mass of the cone, in terms of  $x$ .

.....g  
(4)