

Name:

Exam Style Questions

Pressure



Corbettmaths

Equipment needed: Pen, Calculator

Guidance

1. Read each question carefully before you begin answering it.
2. Check your answers seem right.
3. Always show your workings

Video Tutorial

www.corbettmaths.com/contents

Video 385



Answers and Video Solutions



1. Find the pressure exerted by a force of 8000 newtons on an area of 25m^2 .
Give your answer in newtons/ m^2



.....newtons/ m^2
(2)

2. A crate exerts a force of 120 newtons on a table.
The pressure on the table is $15\text{ newtons}/\text{m}^2$.
Calculate the area of the crate that is in contact with the table.
Include suitable units.



.....
(3)

3. A box is placed on the floor.
The area of the box in contact with the floor is 2.4m^2
The pressure exerted on the floor is $16\text{ newtons}/\text{m}^2$
Work out the force exerted by the box on the floor.



.....N
(2)

4. An object is placed on a table.
It exerts a force of 22 newtons on the table.
The pressure on the table is $500\text{ newtons}/\text{m}^2$
Calculate the area of the crate that is in contact with the table.
Include suitable units.



.....
(3)

5. Find the pressure exerted by a force of 240 newtons on an area of 30cm^2 .
Give your answer in newtons/ m^2



.....newtons/ m^2
(2)

6. The cuboid and the cube below are placed on the floor.



The cuboid has a weight of 60N
The cube has a weight of 40N

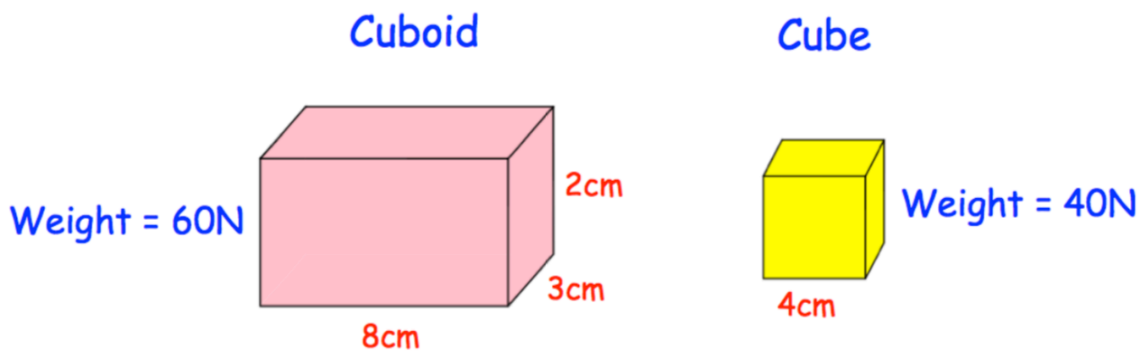

Which exerts a greater pressure on the ground?
You must show your working.

.....
(4)

7. A television is placed on a table.



The area of the television in contact with the table is 750cm^2
The pressure on the table is 1760 newtons/m^2 .

Work out the force exerted by the television on the table.

.....N
(3)

8. A cuboid trunk is placed on a table.



The trunk exerts a pressure of 150 newtons/m^2 on the table.
The trunk exerts a force of 900 newtons on the table.

The trunk has a width of 1.5m
The trunk has a height of 0.8m from the table.

Calculate the volume of the trunk

..... m^3
(4)

9. A cylinder is placed on the ground.
The cylinder has a weight of 85N and a radius of 2cm.



Work out the pressure on the ground in newtons/cm²

.....N/cm²
(4)

10. A lead rod is placed on a table.
The rod is a cylinder with diameter 8cm and height 20cm.



The force exerted on the table is 111.72 newtons.

Work out the pressure in newtons/m²

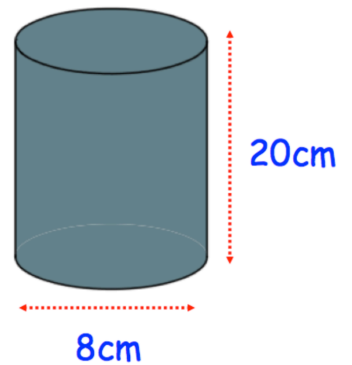

.....newtons/m²
(4)

11. The pressure of a tyre is 34 pounds per square inch.



Given 1 pound = 0.4536 kilograms
 1 inch = 2.54 centimetres

Work out the pressure in grams per square centimetre.

.....g/cm²
(3)

12. The pressure of a football is 500 grams per square centimetre.



Given 1 pound = 0.4536 kilograms
 1 inch = 2.54 centimetres

Work out the pressure in pounds per square inch.

.....psi
(3)

13. A square based pyramid, with a perpendicular height of 15cm is placed on a table.



The weight of the pyramid is 70.56N

The pyramid exerts a pressure of 4900N/m² on the table.

Work out the volume of the square based pyramid.

.....cm³
(5)

14. Containers A and B are placed on a shelf.
Both containers are cylinders.

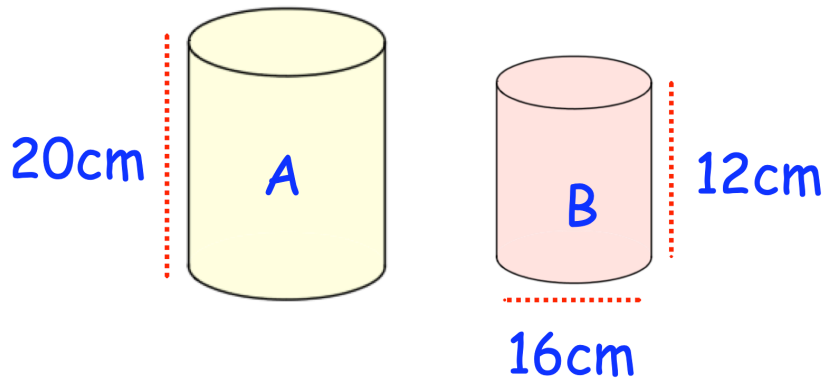

The pressure on the shelf from container B is 3 newtons/cm²

The volume of A : volume of B = 5 : 4

The force exerted by A : force exerted by B = 10 : 7

Work out the pressure on the shelf due to container A.

..... newtons/cm²
(5)