

Name:

Exam Style Questions

## Surface Area of a Cylinder



Corbettmaths

Equipment needed: Calculator, pen

### Guidance

1. Read each question carefully before you begin answering it.
2. Check your answers seem right.
3. Always show your workings

Video Tutorial

[www.corbettmaths.com/contents](http://www.corbettmaths.com/contents)

Video 315



Answers and Video Solutions



1. Below is a cylinder with radius 2cm and height 5cm.

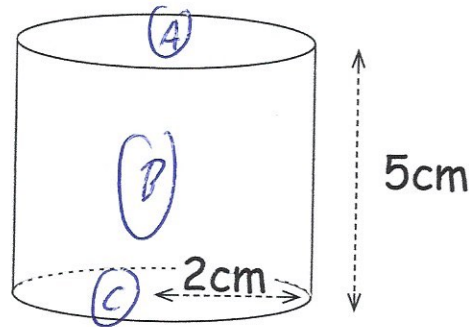

Calculate the surface area of the cylinder.

$$\begin{aligned} \text{(A)} \quad \pi \times 2^2 &= 12.56637061 \quad (4\pi) \\ \text{(C)} \quad \pi \times 2^2 &= 12.56637061 \quad (4\pi) \\ \text{(B)} \quad \pi \times 4 \times 5 &= 62.83185307 \quad (20\pi) \\ &\hline &87.9645943 \end{aligned}$$

$$\begin{aligned} &\dots 87.96 \dots \text{cm}^2 \\ \text{or } &28\pi \quad (3) \end{aligned}$$

2. Shown below is a cylinder.

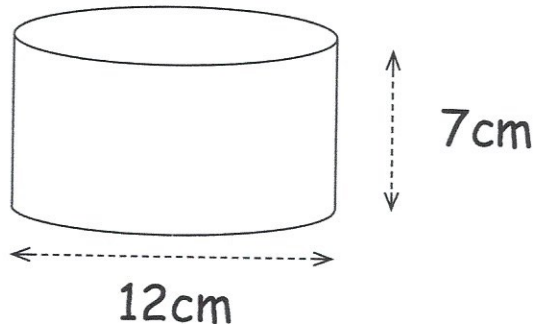

Calculate the curved surface area.  
Give your answer to 1 decimal place.

$$\pi \times 12 \times 7 = 263.8937829 \dots \text{cm}^2 \\ (84\pi)$$

$$\begin{aligned} &\dots 263.9 \dots \text{cm}^2 \\ &(2) \end{aligned}$$

3. A cylindrical container is used to store crisps.  
The radius of the container is 3.8cm and the height is 23cm.

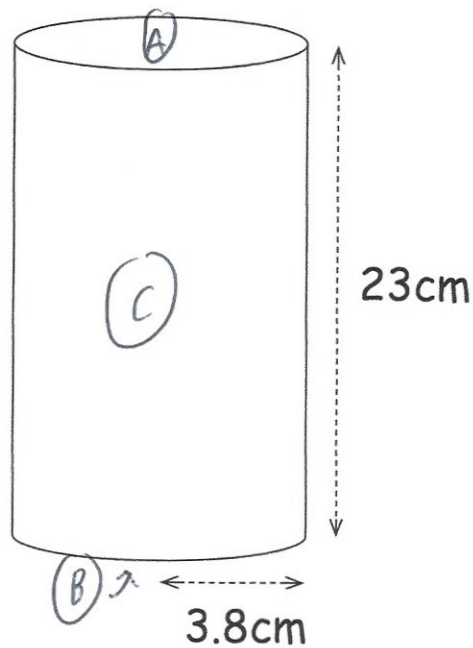

Calculate the surface area of the container.

$$\begin{array}{r}
 (A) \quad \pi \times 3.8^2 = 45.36459792 \quad (14.44\pi) \\
 (B) \quad \pi \times 3.8^2 = 45.36459792 \quad (14.44\pi) \\
 (C) \quad \pi \times 7.6 \times 23 = 549.1503958 \quad (174.8\pi) \\
 \hline
 639.8795917 \quad (203.68\pi)
 \end{array}$$

$$\begin{array}{r}
 639.88 \text{ cm}^2 \\
 \dots\dots\dots \\
 (3)
 \end{array}$$

4. Shown below is a cylinder.

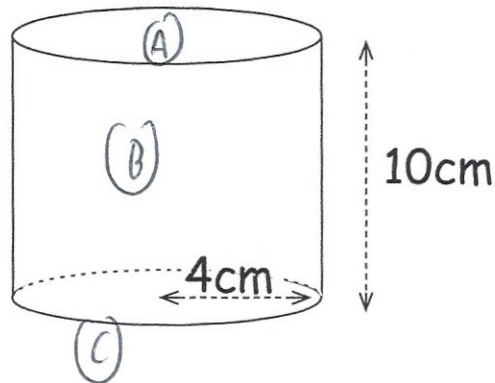

Work out the surface area of the cylinder.  
Give your answer in terms of  $\pi$

(A)  $\pi \times 4^2 = 16\pi$

(B)  $\pi \times 8 \times 10 = 80\pi$

(C)  $\pi \times 4^2 = 16\pi$

$$16\pi + 80\pi + 16\pi$$

.....  $112\pi$  .....  $\text{cm}^2$   
(3)

5. Shown below is a cylinder.

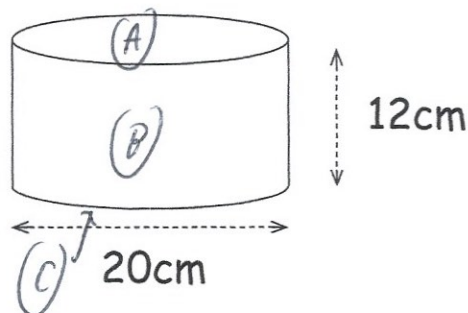

Work out the surface area of the cylinder.  
Give your answer in terms of  $\pi$

(A)  $\pi \times 10^2 = 100\pi$

(B)  $\pi \times 20 \times 12 = 240\pi$

(C)  $\pi \times 10^2 = 100\pi$

.....  $440\pi$  .....  $\text{cm}^2$   
(3)

6. A can of baked beans will have a paper label wrapped around the outside.



The can has a height of 11cm and a radius of 3.5cm.  
The label will cover the entire height of the can.  
The label will have a 1cm overlap vertically so that it can be stuck together.

Calculate the area of the label.

$$\pi \times 7 = 21.99114858$$

$$21.99114858 + 1 = 22.99114858$$

$$22.99114858 \times 11 = 252.90263448$$

$$\underline{252.9} \text{ cm}^2$$

(4)

7. A cylinder has a radius of 8cm.

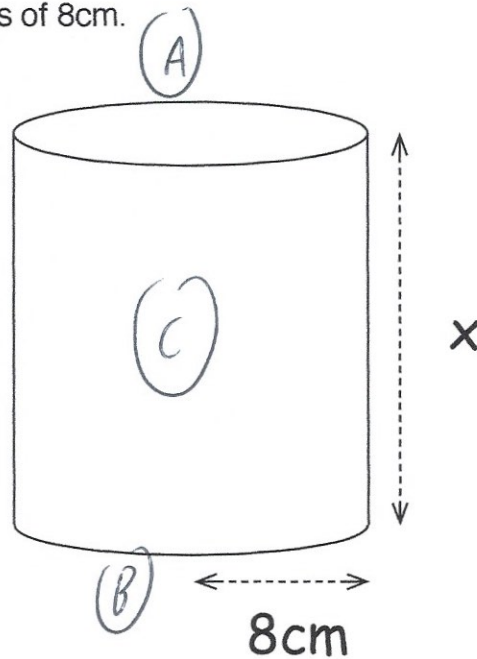

The surface area of the cylinder is  $1200\text{cm}^2$

Work out the height of the cylinder, x.

$$(A) \pi \times 8^2 = 201.0619298 \text{ cm}^2 (64\pi)$$

$$(B) \pi \times 8^2 = 201.0619298 \text{ cm}^2 (64\pi)$$

$$1200 - (2 \times 201.0619\dots) = 797.8761403 \text{ cm}^2$$

$$\pi \times 16 \times x = 797.8761403$$

$$\div 16\pi \quad \div 16\pi$$

$$x = 15.87324\dots$$

$$\begin{array}{r} 15.87 \\ \hline \text{cm} \\ (3) \end{array}$$

8. Shown below is a cylinder with a height of 9cm.

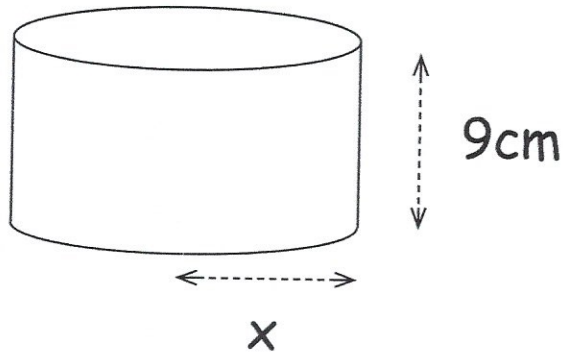

The surface area of the cylinder is  $180\pi \text{ cm}^2$

Work out the radius of the cylinder,  $x$ .

$$\pi x^2 + \pi x^2 + \pi(2x) \times 9 = 180\pi$$

$$2\pi x^2 + 18\pi x = 180\pi$$

$$2x^2 + 18x = 180$$

$$x^2 + 9x = 90$$

$$x^2 + 9x - 90 = 0$$

$$(x+15)(x-6) = 0$$

$$x = -15 \text{ or } x = 6$$

$x$



.....cm  
**(3)**

9.

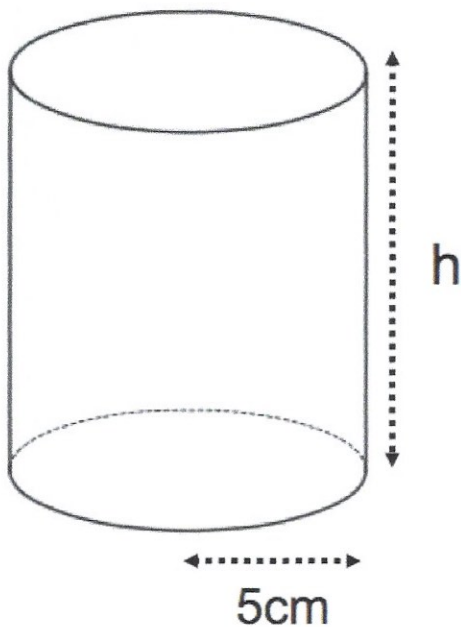

The surface area of the cylinder is  $170\pi$  cm<sup>2</sup>.

Calculate the height of the cylinder.

$$(\pi \times 5^2) + (\pi \times 5^2) + (\pi \times 10 \times h) = 170\pi$$

$$25\pi + 25\pi + 10\pi h = 170\pi$$

$$50\pi + 10\pi h = 170\pi$$

$$10\pi h = 120\pi$$

$$10h = 120$$

$$h = 12$$

.....12.....cm  
(3)

10. On a farm, there is a grain silo.  
The silo is cylindrical with a tile roof.  
The silo has a diameter of 8 metres and is 6 metres tall.



The farmer wants to paint the curved surface of the silo.  
Each can of paint will cover  $20\text{m}^2$ .  
The paint costs £11.75 per can.

How much will it cost the farmer to paint the silo?

$$\pi \times 8 \times 6 = 48\pi \text{ m}^2$$
$$= 150.7964474 \text{ m}^2$$

$$150.7964\dots \div 20 = 7.5398\dots$$

8 cans

$$8 \times 11.75 = \text{£}94$$

£ 94  
(4)

11. Shown below is a prism with a semi-circular cross section.

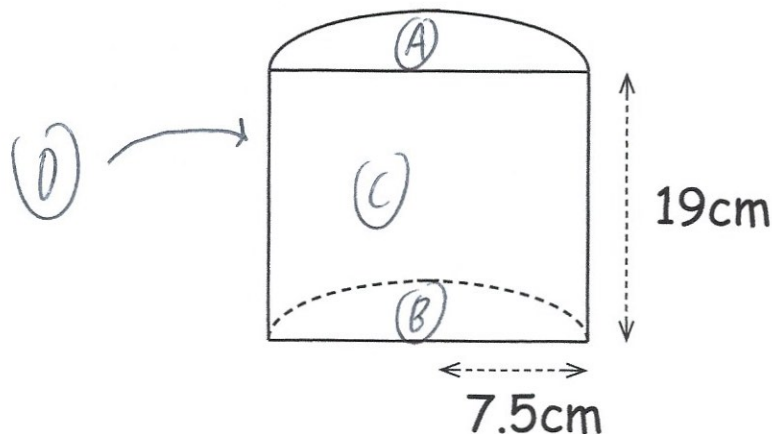

Work out the surface area of the prism.

$$(A) \Rightarrow \frac{1}{2} \times \pi \times 7.5^2 = 88.35729\dots \text{ cm}^2 \quad (28.125\pi)$$

$$(B) \Rightarrow \frac{1}{2} \times \pi \times 7.5^2 = 88.35729\dots \text{ cm}^2 \quad (28.125\pi)$$

$$(C) \Rightarrow 19 \times 15 = 285 \text{ cm}^2$$

$$(D) \Rightarrow \frac{1}{2} \times \pi \times 15 \times 19 = 447.6769531\dots \text{ cm}^2 \quad (142.5\pi)$$

$$(A) + (B) + (C) + (D) = 909.3915399 \text{ cm}^2$$

$$\begin{array}{r} 909.4 \\ \hline \text{cm}^2 \\ (4) \end{array}$$

12. Fleur is creating a piece of equipment for a soft play.



She starts with a cylindrical piece of foam, diameter 50cm and length 1.4m. From the centre of the cylinder, Fleur removes a cylinder with diameter 30cm. Finally she removes the top half of the foam.

The diagram below shows the piece of equipment.

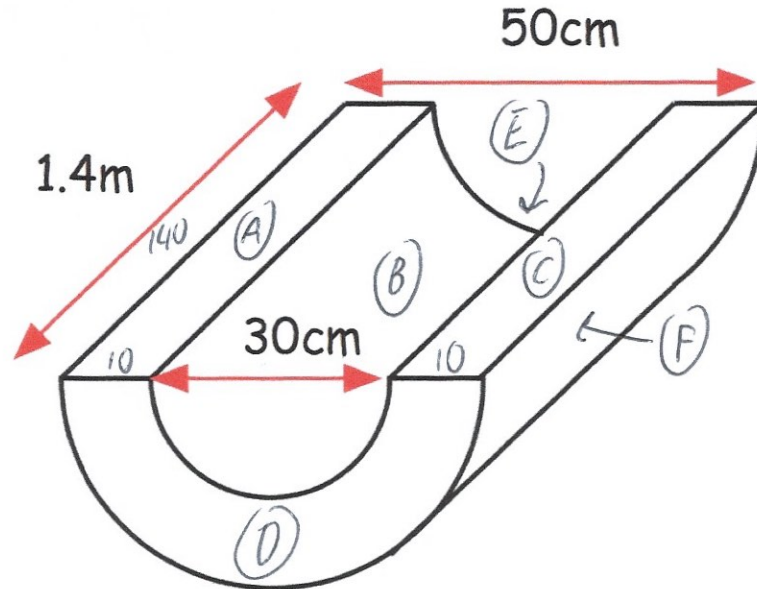

Work out the surface area of the piece of equipment.

$$(A) \quad 140 \times 10 = 1400 \text{ cm}^2$$

$$(C) \quad 140 \times 10 = 1400 \text{ cm}^2$$

$$(B) \quad \frac{1}{2} \times \pi \times 30 \times 140 = 2100\pi \text{ cm}^2$$

$$(F) \quad \frac{1}{2} \times \pi \times 50 \times 140 = 3500\pi \text{ cm}^2$$

$$(D) \quad \frac{1}{2} (\pi \times 25^2 - \pi \times 15^2) = 200\pi \text{ cm}^2$$

$$(E) \quad 200\pi \text{ cm}^2$$

$$1400 + 1400 + 2100\pi + 3500\pi + 200\pi + 200\pi$$

$$2800 + 6000\pi \text{ cm}^2$$

$$\underline{\underline{21649.56 \text{ cm}^2}}$$

(5)

13.

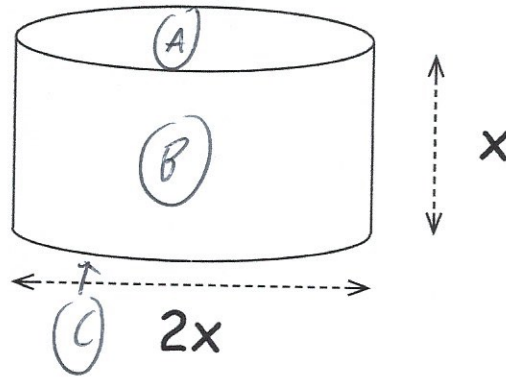

The cylinder above has surface area  $400\pi \text{ cm}^2$

Calculate  $x$ .

- (A)  $\pi x^2$
- (C)  $\pi x^2$
- (B)  $\pi \times 2x \times x = 2\pi x^2$

$$4\pi x^2 = 400\pi$$

$$\pi x^2 = 100\pi$$

$$x^2 = 100$$

$$x = 10$$

10  
.....cm  
(4)

14. A mobile pizza van sells slices of pizza.  
The box they use is shown below.

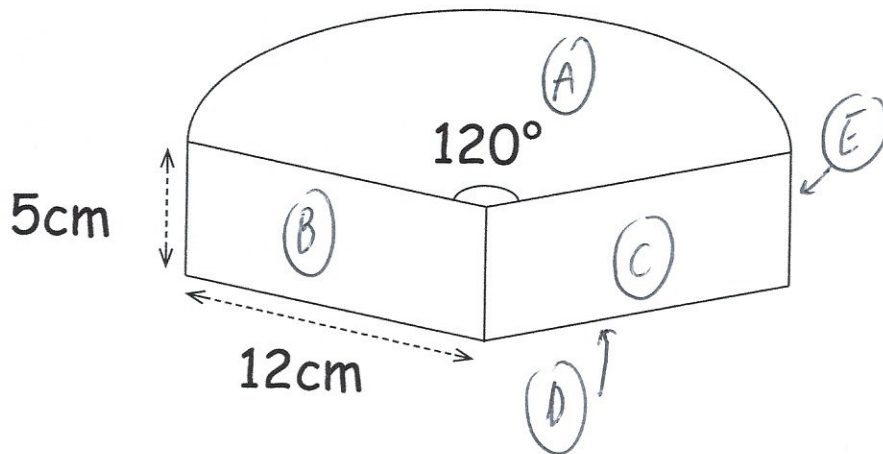

The box is a prism of height 5cm.

The cross-section of the prism is a sector, radius 12cm and angle  $120^\circ$

Find the surface area of the box.

- (A)  $\frac{1}{3} \times \pi \times 12^2 = 48\pi \text{ cm}^2$   
 (B)  $5 \times 12 = 60 \text{ cm}^2$   
 (C)  $5 \times 12 = 60 \text{ cm}^2$   
 (D)  $48\pi \text{ cm}^2$   
 (E)  $\frac{1}{3} \times \pi \times 24 \times 5 = 40\pi \text{ cm}^2$

$$48\pi + 60 + 60 + 48\pi + 40\pi = 547.2566 \dots \text{ cm}^2$$

$$\begin{array}{r} 547.26 \\ \dots\dots\dots \text{cm}^2 \\ (6) \end{array}$$